

# Gate Drivers, High-Speed, Low-Side, Dual 4-A

## FAD3224

### Description

The FAD3224 4-A gate driver is designed to drive N-channel enhancement-mode MOSFETs in low-side switching applications by providing high peak current pulses during the short switching intervals. Internal circuitry provides an und-voltage lockout function by holding the output LOW until the supply voltage is within the operating range. In addition, the drivers feature matched internal propagation delays between A and B channels for applications requiring dual gate drives with critical timing, such as synchronous rectifiers. This also enables connecting two drivers in parallel to effectively double the current capability driving a single MOSFET.

The FAD3224 has dual independent enable pins that default to ON if not connected. If one or both inputs are left unconnected, internal resistors bias the inputs such that the output is pulled LOW to hold the power MOSFET OFF.

### Features

- Industry-Standard Pinouts
- 4.5 V to 30 V Operating Range
- 5 A Peak Sink / Source at  $V_{DD} = 12 V$
- 4.3 A Sink / 2.8 A Source at  $V_{OUT} = 6 V$
- TTL Input Thresholds
- Internal Resistors Turn Driver Off If No Inputs
- 12 ns / 9 ns Typical Rise/Fall Times (2.2 nF Load)
- Under 20 ns Typical Propagation Delay Matched within 2 ns to the Other Channel
- Double Current Capability by Paralleling Channels
- Rated from  $-40\text{ }^{\circ}\text{C}$  to  $+125\text{ }^{\circ}\text{C}$  Ambient
- Automotive Qualified to AEC-Q100
- FAD3224TMX with 4.5 V UVLO
- FAD3224TUMX with 9 V UVLO
- These are Pb-Free Devices

### PACKAGE OUTLINES

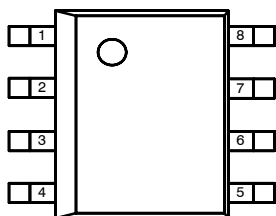
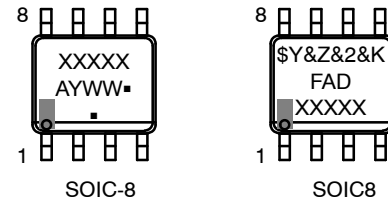

Figure 1. SOIC-8  
(Top View)



### MARKING DIAGRAMS



XXX = Specific Device Code

A = Assembly Lot Code

Y = Year

WW = Work Week

▪ = Pb-Free Package

\$Y = onsemi Logo Graphic

&Z = Assembly Plant Code

&2 = 2-Digit Date Code (Year and Week)

&K = 2-Digit Lot Run Traceability Code

(Note: Microdot may be in either location)

### ORDERING INFORMATION

See detailed ordering and shipping information on page 14 of this data sheet.

### Applications

- Switch-Mode Power Supplies
- High-Efficiency MOSFET Switching
- Synchronous Rectifier Circuits
- DC-to-DC Converters
- Motor Control
- Automotive-Qualified Systems

### Related Resources

- [AN-6069 - Application Review and Comparative Evaluation of Low-Side Gate Drivers](#)

# FAD3224

## THERMAL CHARACTERISTICS (Note 1)

Package	$\Theta_L$ (Note 2)	$\Theta_{JT}$ (Note 3)	$\Theta_{JA}$ (Note 4)	$\Psi_{JB}$ (Note 5)	$\Psi_{JT}$ (Note 6)	Unit
8-Pin Small Outline Integrated Circuit (SOIC)	38	29	150	41	2.3	°C/W

1. Estimates derived from thermal simulation; actual values depend on the application.
2.  $\Theta_{JL}$  ( $\Theta_{JL}$ ): Thermal resistance between the semiconductor junction and the bottom surface of all the leads (including any thermal pad) that are typically soldered to a PCB.
3.  $\Theta_{JT}$  ( $\Theta_{JT}$ ): Thermal resistance between the semiconductor junction and the top surface of the package, assuming it is held at a uniform temperature by a top-side heatsink.
4.  $\Theta_{JA}$  ( $\Theta_{JA}$ ): Thermal resistance between junction and ambient, dependent on the PCB design, heat sinking, and airflow. The value given is for natural convection with no heatsink using a 2S2P board, as specified in JEDEC standards JESD51-2, JESD51-5, and JESD51-7, as appropriate.
5.  $\Psi_{JB}$  ( $\Psi_{JB}$ ): Thermal characterization parameter providing correlation between semiconductor junction temperature and an application circuit board reference point for the thermal environment defined in Note 4. For the SOIC-8-EP package, the board reference is defined as the PCB copper connected to the thermal pad and protruding from either end of the package. For the SOIC-8 package, the board reference is defined as the PCB copper adjacent to pin 6.
6.  $\Psi_{JT}$  ( $\Psi_{JT}$ ): Thermal characterization parameter providing correlation between the semiconductor junction temperature and the center of the top of the package for the thermal environment defined in Note 4.

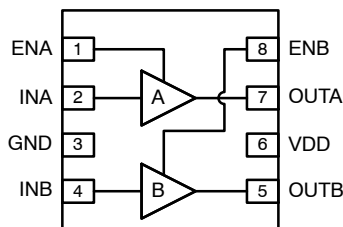

Figure 2. Pin Assignment

## PIN DEFINITIONS

Name	Pin Description
ENA	Enable Input for Channel A. Pull pin LOW to inhibit driver A. ENA has TTL thresholds for INx threshold
ENB	Enable Input for Channel B. Pull pin LOW to inhibit driver B. ENB has TTL thresholds INx threshold
GND	Ground. Common ground reference for input and output circuits
INA	Input to Channel A
INB	Input to Channel B
OUTA	Gate Drive Output A: Held LOW unless required input(s) are present and $V_{DD}$ is above UVLO threshold
OUTB	Gate Drive Output B: Held LOW unless required input(s) are present and $V_{DD}$ is above UVLO threshold
VDD	Supply Voltage. Provides power to the IC

## OUTPUT LOGIC

ENx	INx	OUTx
0	0 (Note 7)	0
0	1	0
1 (Note 7)	0 (Note 7)	0
1 (Note 7)	1	1

7. Default input signal if no external connection is made.

# FAD3224

## BLOCK DIAGRAMS

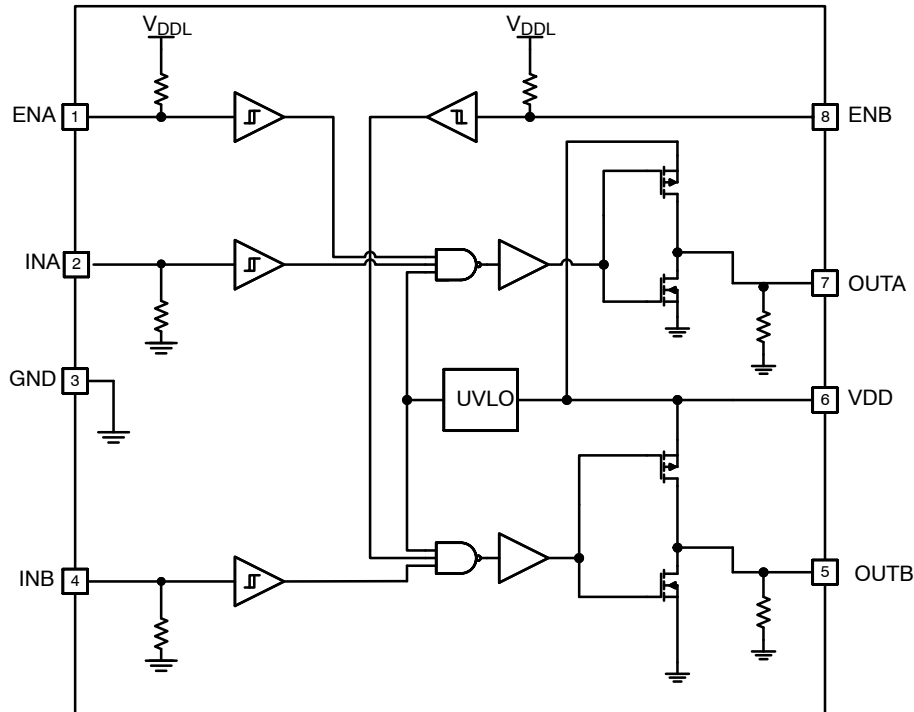

Figure 3. FAD3224 Block Diagram

### ABSOLUTE MAXIMUM RATINGS

Symbol	Parameter	Min	Max	Unit	
$V_{DD}$	VDD to PGND	-0.3	33.0	V	
$V_{EN}$	ENA and ENB to GND	GND - 10	30.0	V	
$V_{IN}$	INA and INB to GND	GND - 10	30.0	V	
$V_{OUT}$	OUTA and OUTB to GND	Repetitive Pulse < 200 ns (Note 9)	-2.0	$V_{DD} + 0.3$	V
		DC	GND - 0.3	$V_{DD} + 0.3$	V
$ESD_{HBM}$	ESD Capability, Human Body Model (Note 8)	-	2	kV	
$T_L$	Lead Soldering Temperature (10 Seconds)	-	+260	°C	
$T_J$	Junction Temperature	-55	+150	°C	
$T_{STG}$	Storage Temperature	-65	+150	°C	
$I_{OUT\_DIODE}$	Output Body Diode DC Current (OUTA, OUTB) (Note 9) (Note 10)	-	0.2	A	
$I_{OUT}$	Output Current (OUTA and OUTB to GND)	Repetitive Pulse < 500 ns (Note 9)	-	5	A
		DC (Note 9)	-	0.4	A

Stresses exceeding those listed in the Maximum Ratings table may damage the device. If any of these limits are exceeded, device functionality should not be assumed, damage may occur and reliability may be affected.

8. This device series incorporates ESD protection and is tested by the following methods:

ESD Human Body Model tested per ANSI/ESDA/JDEC JS-001-2012

ESD Charged Device Model tested per JESD22-C101

9. Not Tested in production. Typical frequency of 1kHz. For pulse current & voltage, when increasing frequency above 1 kHz, value can be as low as DC values.

10. Reverse Current going back to OUT-VDD bulk diode (IN = H) or going out OUT-GND bulk diode (IN = L) should not be greater than this.

# FAD3224

## RECOMMENDED OPERATING CONDITIONS

Symbol	Parameter	Min	Max	Unit
V <sub>DD</sub>	Supply Voltage Range	4.5	30.0	V
V <sub>DD</sub>	Supply Voltage Range (FAD3224TU only)	9.5	30.0	V
V <sub>EN</sub>	Enable Voltage ENA and ENB	0	28	V
V <sub>IN</sub>	Input Voltage INA and INB	0	28	V
V <sub>OUT</sub>	OUTA and OUTB to GND	0	V <sub>DD</sub>	V
T <sub>A</sub>	Operating Ambient Temperature	-40	+125	°C

Functional operation above the stresses listed in the Recommended Operating Ranges is not implied. Extended exposure to stresses beyond the Recommended Operating Ranges limits may affect device reliability.

## ELECTRICAL CHARACTERISTICS

(Unless otherwise noted, V<sub>DD</sub> = 12 V, T<sub>J</sub> = -40 °C to +125 °C. Currents are defined as positive into the device and negative out of the device.)

Symbol	Parameter	Characteristic	Min	Typ	Max	Unit
--------	-----------	----------------	-----	-----	-----	------

### SUPPLY [FAD3224T(MX)-F085]

V <sub>DD</sub>	Operating Range		4.5	-	30.0	V
I <sub>DD</sub>	Supply Current, Inputs / EN Not Connected		-	0.70	1.20	mA
V <sub>ON</sub>	Turn-On Voltage	INA = ENA = V <sub>DD</sub> , INB = ENB = 0 V	3.5	3.9	4.3	V
V <sub>OFF</sub>	Turn-Off Voltage	INA = ENA = V <sub>DD</sub> , INB = ENB = 0 V	3.3	3.7	4.1	V

### SUPPLY [FAD3224TU(MX)-F085 (Modified UVLO Version)]

V <sub>DD</sub>	Operating Range		9.5		30.0	V
I <sub>DD</sub>	Supply Current, Inputs / EN Not Connected		-	0.70	1.20	mA
V <sub>ON</sub>	Turn-On Voltage	INA = ENA = V <sub>DD</sub> , INB = ENB = 0 V	8.0	9.1	10.2	V
V <sub>OFF</sub>	Turn-Off Voltage	INA = ENA = V <sub>DD</sub> , INB = ENB = 0 V	7.0	8.2	9.3	V

### INPUTS [FAD3224(T/TU)(MX)-F085]

V <sub>INL_T</sub>	INx Logic LOW Threshold		0.8	1.2	-	V
V <sub>INH_T</sub>	INx Logic HIGH Threshold		-	1.6	2.0	V
V <sub>HYS_T</sub>	TTL Logic Hysteresis Voltage		-	0.4	0.9	V
I <sub>IN_T</sub>	Non-inverting Input Current	IN from 0 to V <sub>DD</sub>	-	-	50	μA

### ENABLE [FAD3224(T/TU)(MX)-F085]

V <sub>ENL</sub>	Enable Logic Low Threshold	EN from 5 V to 0 V	0.8	1.2	-	V
V <sub>ENH</sub>	Enable Logic High Threshold	EN from 0 V to 5 V	-	1.6	2.0	V
V <sub>HYS_T</sub>	TTL Logic Hysteresis Voltage (Note 10)		-	0.4	-	V
R <sub>PU</sub>	Enable Pull-Up Resistance (Note 11)		-	400	-	kΩ
t <sub>D3</sub>	EN to Output Propagation Delay (Note 12)	0 V to 5 V EN, 1 V/ns Slew Rate	9	17	29	ns
t <sub>D4</sub>		5 V to 0 V EN, 1 V/ns Slew Rate	9	17	29	ns

# FAD3224

## ELECTRICAL CHARACTERISTICS

(Unless otherwise noted,  $V_{DD} = 12\text{ V}$ ,  $T_J = -40\text{ }^\circ\text{C}$  to  $+125\text{ }^\circ\text{C}$ . Currents are defined as positive into the device and negative out of the device.)

Symbol	Parameter	Characteristic	Min	Typ	Max	Unit
<b>OUTPUTS [FAD3224(T/TU)(MX)-F085]</b>						
$I_{PK\_SINK}$	OUT Current, Peak, Sinking (Note 11)	$C_{LOAD} = 0.22\ \mu\text{F}$ , $f = 1\ \text{kHz}$	3.7	4.5	5	A
$I_{PK\_SOURCE}$	OUT Current, Peak, Sourcing (Note 11)	$C_{LOAD} = 0.22\ \mu\text{F}$ , $f = 1\ \text{kHz}$	5.2	6.3	7	A
$t_{RISE}$	Output Rise Time (Note 12)	$C_{LOAD} = 2200\ \text{pF}$	-	12	20	ns
$t_{FALL}$	Output Fall Time (Note 12)	$C_{LOAD} = 2200\ \text{pF}$	-	9	17	ns
$t_{DEL\_MATCH}$	Propagation Matching Between Channels	$I_{NA} = I_{NB}$ , $O_{UTA}$ and $O_{UTB}$ at 50% Point	-	2	4	ns
$t_{D1}, t_{D2}$	Output Propagation Delay, TTL Inputs (Note 12)	$0 - 5\ V_{IN}$ , $1\ \text{V/ns}$ Slew Rate	9	17	29	ns
$V_{DD} - V_{OH}$	High Level Output Voltage	$I_{OUT} = -10\ \text{mA}$	-	5	35	mV
$V_{OL}$	Low Level Output Voltage	$I_{OUT} = 10\ \text{mA}$	-	5	25	mV

Product parametric performance is indicated in the Electrical Characteristics for the listed test conditions, unless otherwise noted. Product performance may not be indicated by the Electrical Characteristics if operated under different conditions.

11. Not tested in production.

12. See Timing Diagrams of Figures 4 and 5. The propagation values are Guaranteed by Design.

## TIMING DIAGRAMS

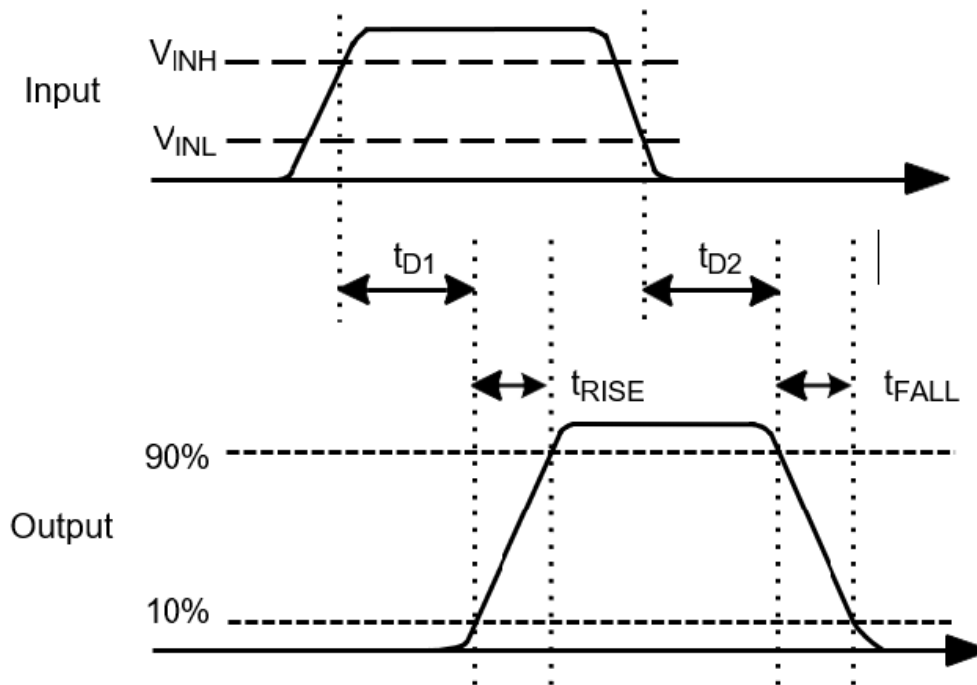

Figure 4. (EN HIGH or Floating)

FAD3224

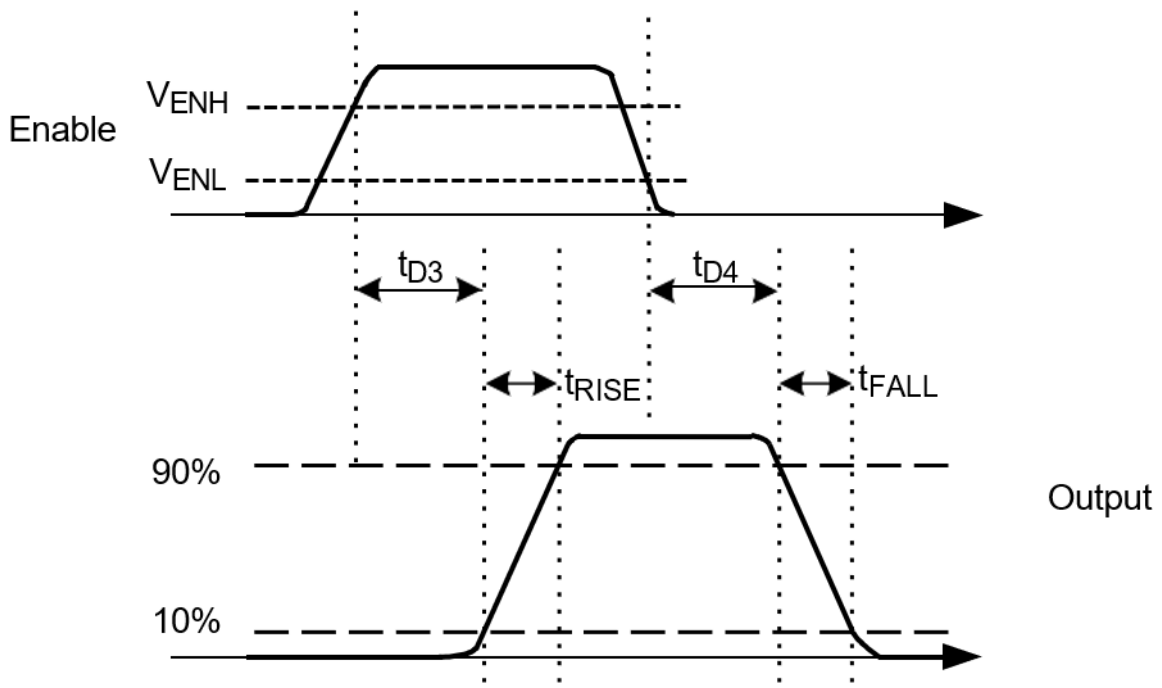

Figure 5. (IN HIGH)

**TYPICAL PERFORMANCE CHARACTERISTICS**

TYPICAL CHARACTERISTICS ARE PROVIDED AT 25 °C AND  $V_{DD} = 12\text{ V}$  UNLESS OTHERWISE NOTED.

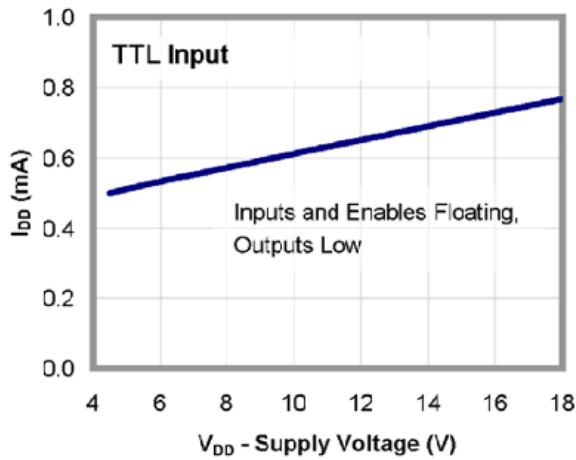

Figure 6.  $I_{DD}$  (Static) vs. Supply Voltage (Note 14)

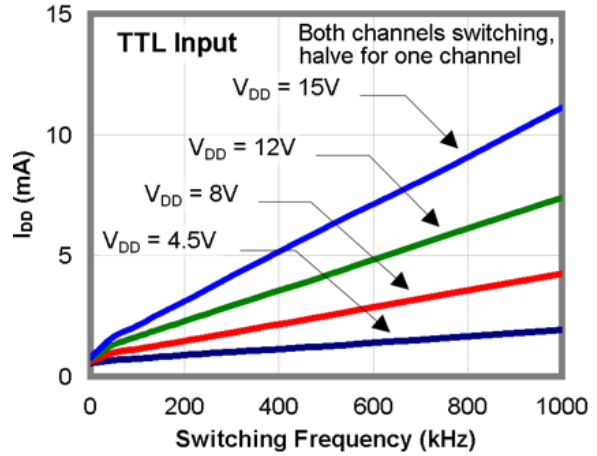

Figure 7.  $I_{DD}$  (No-Load) vs. Frequency

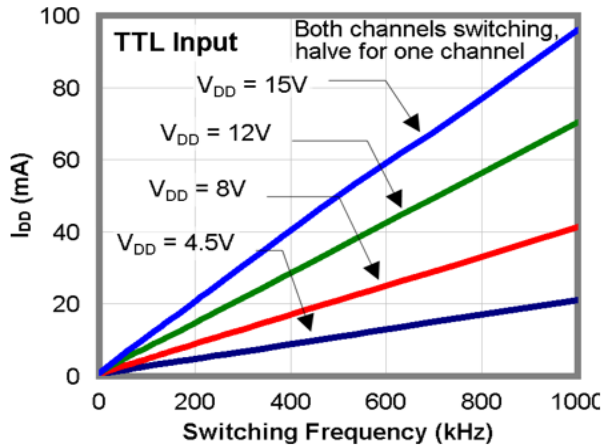

Figure 8.  $I_{DD}$  (2.2 nF Load) vs. Frequency

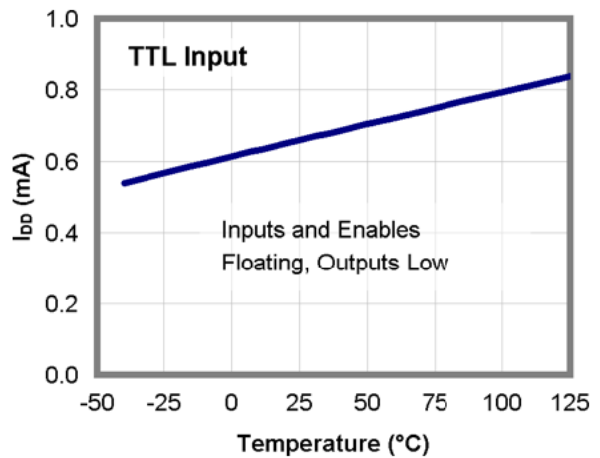

Figure 9.  $I_{DD}$  (Static) vs. Temperature (Note 14)

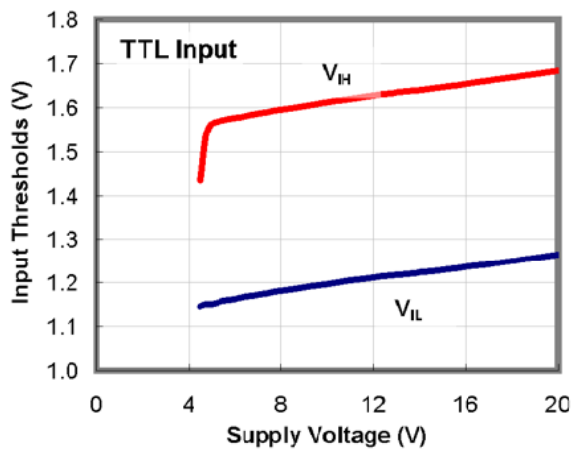

Figure 10. Input Thresholds vs. Supply Voltage

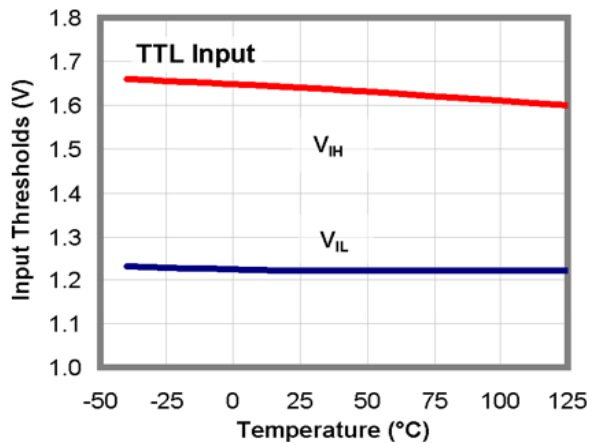

Figure 11. Input Thresholds vs. Temperature

TYPICAL PERFORMANCE CHARACTERISTICS

TYPICAL CHARACTERISTICS ARE PROVIDED AT 25 °C AND  $V_{DD} = 12$  V UNLESS OTHERWISE NOTED. (CONTINUED)

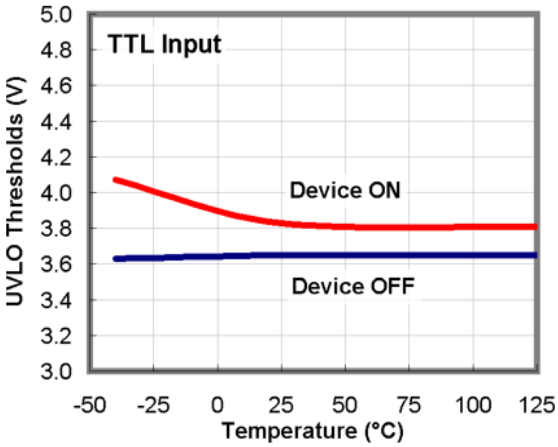

Figure 12. UVLO Threshold vs. Temperature

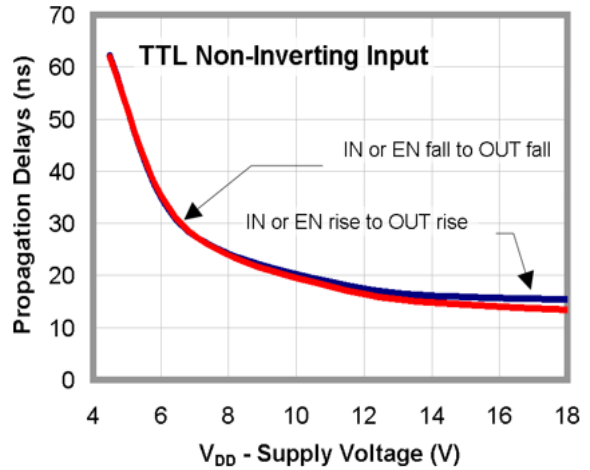

Figure 13. Propagation Delay vs. Supply Voltage

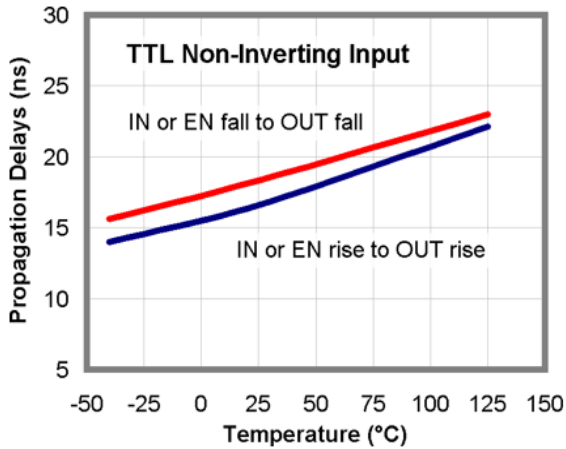

Figure 14. Propagation Delays vs. Temperature

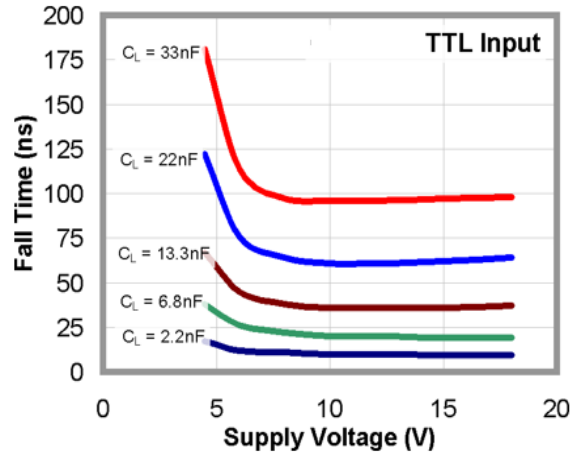

Figure 15. Fall Time vs. Supply Voltage

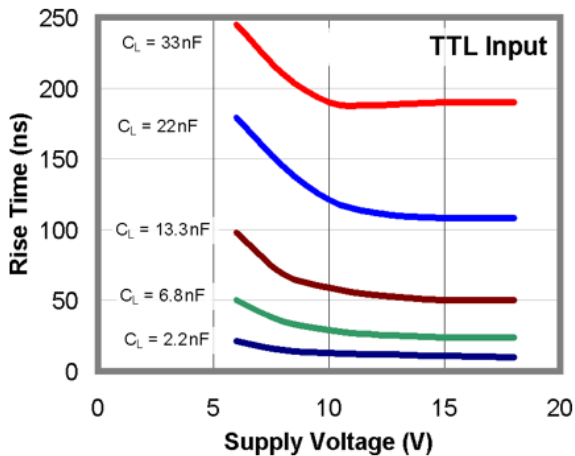

Figure 16. Rise Time vs. Supply Voltage

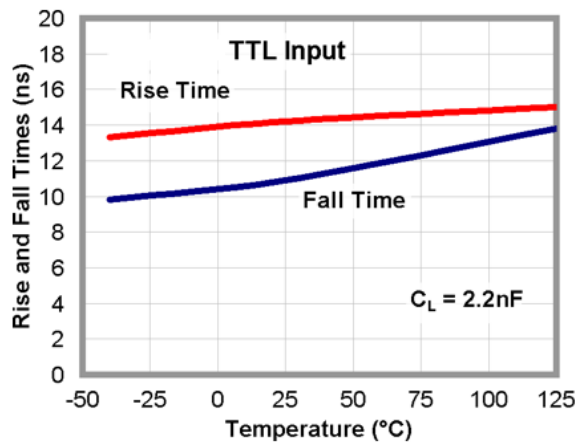

Figure 17. Rise and Fall Times vs. Temperature

TYPICAL PERFORMANCE CHARACTERISTICS

TYPICAL CHARACTERISTICS ARE PROVIDED AT 25 °C AND  $V_{DD} = 12\text{ V}$  UNLESS OTHERWISE NOTED. (CONTINUED)

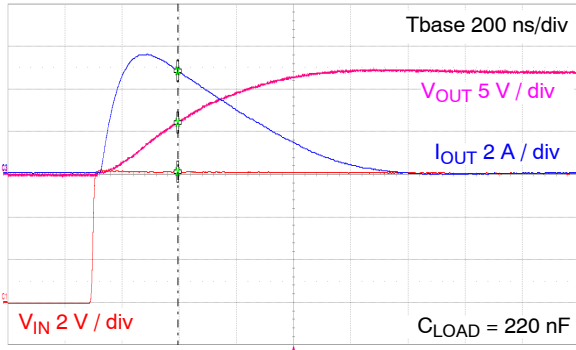

Figure 18. Quasi-Static Source Current

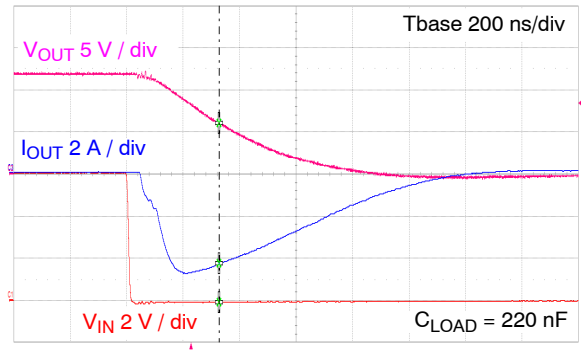

Figure 19. Quasi-Static Sink Current

# FAD3224

## TEST CIRCUIT

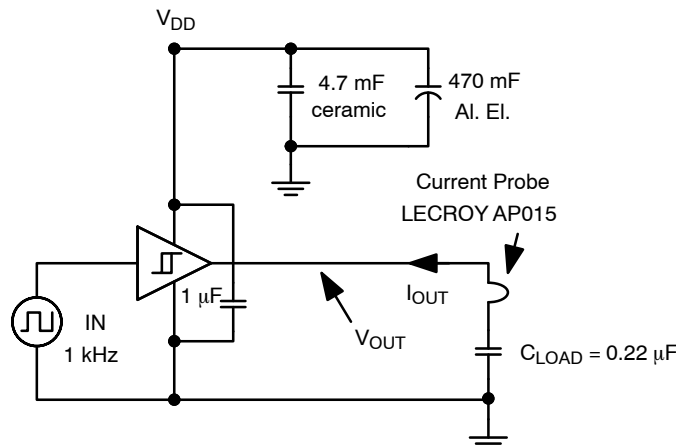

Figure 20. Quasi-Static  $I_{OUT}$  /  $V_{OUT}$  Test Circuit

## APPLICATIONS INFORMATION

### Input Thresholds

Each member of the FAD322x driver family consists of two identical channels that may be used independently at rated current or connected in parallel to double the individual current capacity. In the FAD3224, channels A and B can be enabled or disabled independently using ENA or ENB, respectively. The EN pin has TTL thresholds for parts with TTL input thresholds. If ENA and ENB are not connected, an internal pull-up resistor enables the driver channels by default. ENA and ENB have TTL thresholds in parts with TTL INx threshold.

If the channel A and channel B inputs and outputs are connected in parallel to increase the driver current capacity, ENA and ENB should be connected and driven together. In addition, it is recommended to include an individual gate resistance for each channel output to limit the shoot through current possibly happening between the two channels due to variations in propagation delay or in input threshold between the two channels.

The FAD3224 family offers TTL input thresholds. In the FAD3224, the input thresholds meet industry-standard TTL-logic thresholds independent of the  $V_{DD}$  voltage, and there is a hysteresis voltage of approximately 0.4 V. These levels permit the inputs to be driven from a range of input logic signal levels for which a voltage over 2 V is considered logic HIGH. The driving signal for the TTL inputs should have fast rising and falling edges with a slew rate of 6 V/ $\mu$ s or faster, so a rise time from 0 to 3.3 V should be 550 ns or less. With reduced slew rate, circuit noise could cause the driver input voltage to exceed the hysteresis voltage and retrigger the driver input, causing erratic operation.

### Static Supply Current

In the  $I_{DD}$  (static) typical performance characteristics (Figure 6 and Figure 9), the curve is produced with all inputs/enables floating (OUT is low) and indicates the lowest static  $I_{DD}$  current for the tested configuration. For other states, additional current flows through the 100 k $\Omega$  resistors on the inputs and outputs shown in the block diagram (see Figure 3). In these cases, the actual static  $I_{DD}$  current is the value obtained from the curves plus this additional current.

### Under-Voltage Lockout

The FAD3224 startup logic is optimized to drive ground-referenced N-channel MOSFETs with an under-voltage lockout (UVLO) function to ensure that the IC starts up in an orderly fashion. When  $V_{DD}$  is rising, yet below the UVLO level, this circuit holds the output LOW, regardless of the status of the input pins. After the part is active, the supply voltage must drop 0.2 V before the part shuts down. This hysteresis helps prevent chatter when low  $V_{DD}$  supply voltages have noise from the power switching. This configuration is not suitable for driving high-side P-channel MOSFETs because the low output voltage of the driver would turn the P-channel MOSFET ON with  $V_{DD}$  below the UVLO level.

### V<sub>DD</sub> Bypass Capacitor Guidelines

To enable this IC to turn a device ON quickly, a local high-frequency bypass capacitor, C<sub>BYP</sub>, with low ESR and ESL should be connected between the V<sub>DD</sub> and GND pins with minimal trace length. This capacitor is in addition to the bulk electrolytic capacitance of 10 μF to 47 μF commonly found on the driver and controller bias circuits. A typical criterion for choosing the value of C<sub>BYP</sub> is to keep the ripple voltage on the V<sub>DD</sub> supply to ≤5%. This is often achieved with a value ≥20 times the equivalent load capacitance C<sub>EQV</sub>, defined here as Q<sub>GATE</sub>/V<sub>DD</sub>. Ceramic capacitors of 0.1 μF to 1 μF or larger are common choices, as are dielectrics, such as X5R and X7R with good temperature characteristics and high pulse current capability.

If circuit noise affects normal operation, the value of C<sub>BYP</sub> may be increased to 50-100 times the C<sub>EQV</sub>, or C<sub>BYP</sub> may be split into two capacitors. One should be a larger value, based on equivalent load capacitance, and the other a smaller value, such as 1-10 nF mounted closest to the V<sub>DD</sub> and GND pins to carry the higher frequency components of the current pulses. The bypass capacitor must provide the pulsed current from both of the driver channels and, if the drivers are switching simultaneously, the combined peak current sourced from the C<sub>BYP</sub> would be twice as large as when a single channel is switching.

### Layout and Connection Guidelines

The FAD3224 family of gate drivers incorporates fast-reacting input circuits, short propagation delays, and powerful output stages capable of delivering current peaks over 4 A to facilitate voltage transition times from under 10 ns to over 150 ns. The following layout and connection guidelines are strongly recommended:

- Keep high-current output and power ground paths separate logic and enable input signals and signal ground paths. This is especially critical when dealing with TTL-level logic thresholds at driver inputs and enable pins.
- Keep the driver as close to the load as possible to minimize the length of high-current traces. This reduces the series inductance to improve high-speed switching, while reducing the loop area that can radiate EMI to the driver inputs and surrounding circuitry.
- If the inputs to a channel are not externally connected, the internal 400 kΩ resistors indicated on block diagrams command a low output. In noisy environments, it may be necessary to tie inputs of an unused channel to V<sub>DD</sub> or GND using short traces to prevent noise from causing spurious output switching.
- Many high-speed power circuits can be susceptible to noise injected from their own output or other external sources, possibly causing output re-triggering. These effects can be obvious if the circuit is tested in breadboard or non-optimal circuit layouts with long input, enable, or output leads. For best results, make connections to all pins as short and direct as possible.

- The FAD3224 is compatible with many other industry-standard drivers. In single input parts with enable pins, there is an internal 400 kΩ resistor tied to V<sub>DD</sub> to enable the driver by default; this should be considered in the PCB layout.
- The turn-on and turn-off current paths should be minimized, as discussed in the following section

Figure 21 shows the pulsed gate drive current path when the gate driver is supplying gate charge to turn the MOSFET ON. The current is supplied from the local bypass capacitor, C<sub>BYP</sub>, and flows through the driver to the MOSFET gate and to ground. To reach the high peak currents possible, the resistance and inductance in the path should be minimized. The localized C<sub>BYP</sub> acts to contain the high peak current pulses within this driver-MOSFET circuit, preventing them from disturbing the sensitive analog circuitry in the PWM controller.

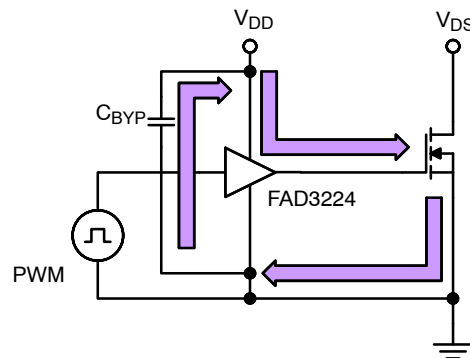

Figure 21. Current Path for MOSFET Turn-On

Figure 22 shows the current path when the gate driver turns the MOSFET OFF. Ideally, the driver shunts the current directly to the source of the MOSFET in a small circuit loop. For fast turn-off times, the resistance and inductance in this path should be minimized.

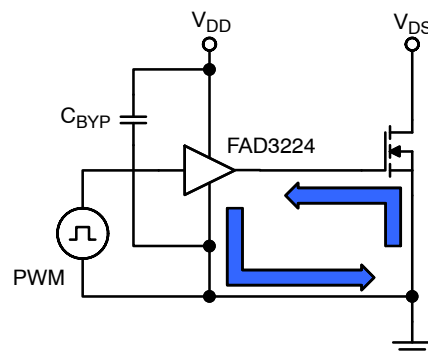
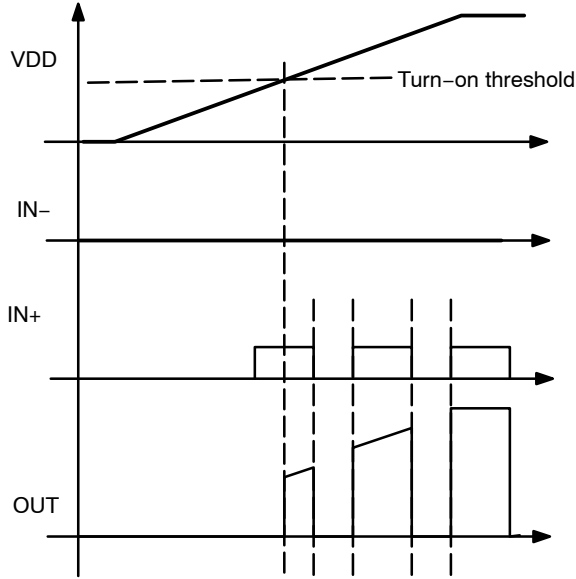

Figure 22. Current Path for MOSFET Turn-Off

**Operational Waveforms**

At power-up, the driver output remains LOW until the  $V_{DD}$  voltage reaches the turn-on threshold. The magnitude of the OUT pulses rises with  $V_{DD}$  until steady-state  $V_{DD}$  is reached. The non-inverting operation illustrated in Figure 23 shows that the output remains LOW until the UVLO threshold is reached, then the output is in-phase with the input.



**Figure 23. Startup Waveforms**

**Thermal Guidelines**

Gate drivers used to switch MOSFETs and IGBTs at high frequencies can dissipate significant amounts of power. It is important to determine the driver power dissipation and the resulting junction temperature in the application to ensure that the part is operating within acceptable temperature limits.

The total power dissipation in a gate driver is the sum of two components,  $P_{GATE}$  and  $P_{DYNAMIC}$ :

$$P_{TOTAL} = P_{GATE} + P_{DYNAMIC} \quad (eq. 1)$$

$P_{GATE}$  (Gate Driving Loss): The most significant power loss results from supplying gate current (charge per unit time) to switch the load MOSFET on and off at the switching frequency. The power dissipation that results from driving a MOSFET at a specified gate-source voltage,  $V_{GS}$ , with gate charge,  $Q_G$ , at switching frequency,  $f_{SW}$ , is determined by:

$$P_{GATE} = Q_G \times V_{GS} \times f_{SW} \times n \quad (eq. 2)$$

where n is the number of driver channels in use (1 or 2).

$P_{DYNAMIC}$  (Dynamic Pre-Drive / Shoot-through Current): A power loss resulting from internal current

consumption under dynamic operating conditions, including pin pull-up / pull-down resistors. The internal current consumption ( $I_{DYNAMIC}$ ) can be estimated using the graphs in Figure 7 and Figure 8 of the Typical Performance Characteristics to determine the current  $I_{DYNAMIC}$  drawn from  $V_{DD}$  under actual operating conditions:

$$P_{DYNAMIC} = I_{DYNAMIC} \times V_{DD} \times n \quad (eq. 3)$$

where n is the number of driver ICs in use. Note that n is usually be one IC even if the IC has two channels, unless two or more driver ICs are in parallel to drive a large load.

Once the power dissipated in the driver is determined, the driver junction temperature rise with respect to circuit board can be evaluated using the following thermal equation, assuming

$\Psi_{JB}$  was determined for a similar thermal design (heat sinking and air flow):

$$T_J = P_{TOTAL} \times \Psi_{JB} + T_B \quad (eq. 4)$$

where:

$T_J$  = driver junction temperature;

$\Psi_{JB}$  = (psi) thermal characterization parameter relating temperature rise to total power dissipation; and

$T_B$  = board temperature in location as defined in the Thermal Characteristics table.

To give a numerical example, assume for a 12 V  $V_{DD}$  ( $V_{BIAS}$ ) system, the synchronous rectifier switches of Figure 26 have a total gate charge of 60 nC at  $V_{GS} = 7$  V. Therefore, two devices in parallel would have 120 nC gate charge. At a switching frequency of 300 kHz, the total power dissipation is:

$$P_{GATE} = 120 \text{ nC} \times 7 \text{ V} \times 300 \text{ kHz} \times 2 = 0.504 \text{ W} \quad (eq. 5)$$

$$P_{DYNAMIC} = 3.0 \text{ mA} \times 12 \text{ V} \times 1 = 0.036 \text{ W} \quad (eq. 6)$$

$$P_{TOTAL} = 0.540 \text{ W} \quad (eq. 7)$$

The SOIC-8 has a junction-to-board thermal characterization parameter of  $\Psi_{JB} = 42$  °C/W. In a system application, the localized temperature around the device is a function of the layout and construction of the PCB along with airflow across the surfaces. To ensure reliable operation, the maximum junction temperature of the device must be prevented from exceeding the maximum rating of 150 °C; with 80% derating,  $T_J$  would be limited to 120 °C. Rearranging Equation 4 determines the board temperature required to maintain the junction temperature below 120 °C:

$$T_{B, MAX} = T_J - P_{TOTAL} \times \Psi_{JB} \quad (eq. 8)$$

$$T_{B, MAX} = 120^\circ\text{C} - 0.54 \text{ W} \times 42^\circ\text{C/W} = 97^\circ\text{C} \quad (eq. 9)$$

# FAD3224

## TYPICAL APPLICATION DIAGRAMS

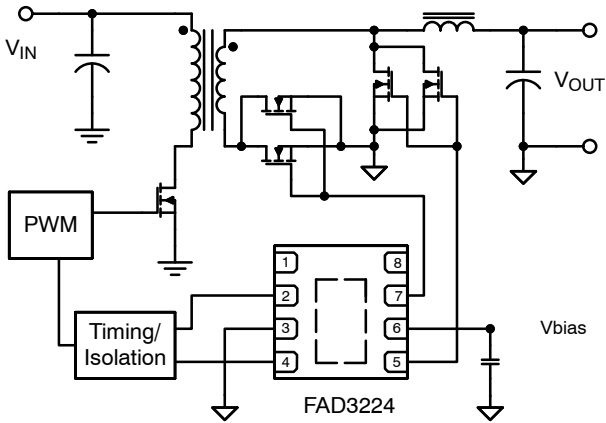

Figure 24. High Current Forward Converter with Synchronous Rectification

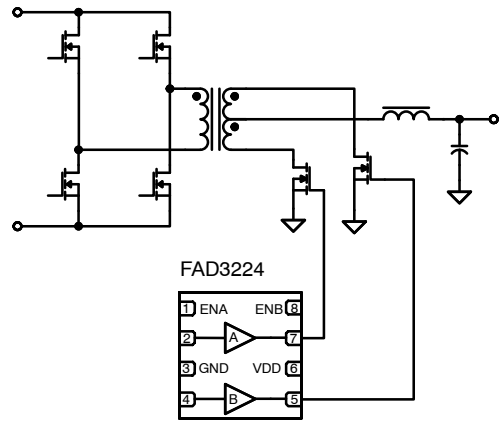

Figure 25. Center-Tapped Bridge Output with Synchronous Rectifiers

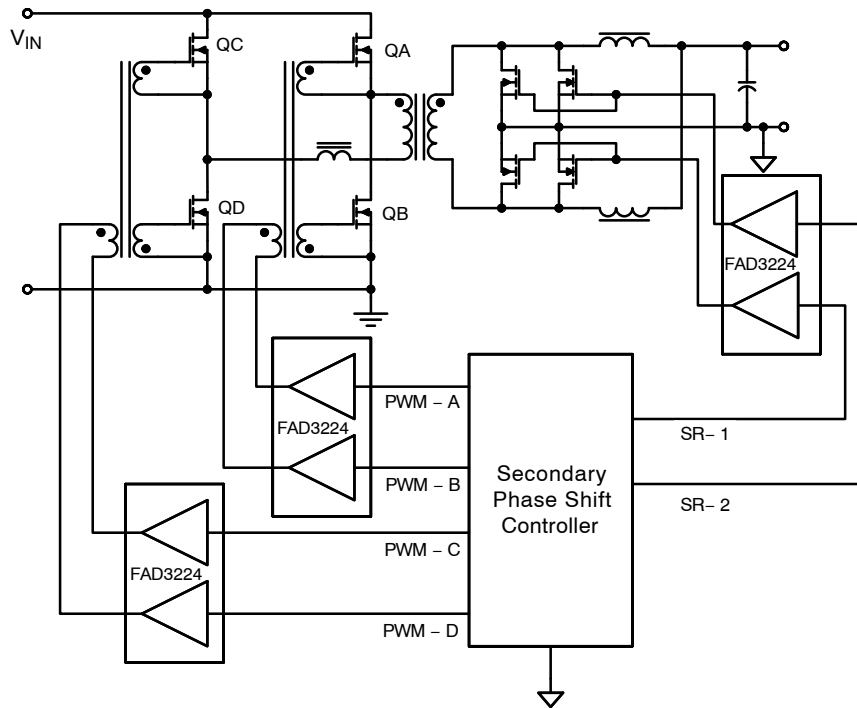

Figure 26. Secondary Controlled Full Bridge with Current Doubler Output, Synchronous Rectifiers (Simplified)

# FAD3224

## ORDERING INFORMATION

Part Number	Logic	Input Threshold	Package	Packing Method	Quantity per Reel
FAD3224TMX-F085	Dual Non-Inverting Channels + Dual Enable	TTL	SOIC-8	Tape & Reel	2,500
FAD3224TUMX-F085 (Note 13)			SOIC-8	Tape & Reel	2,500

† For information on tape and reel specifications, including part orientation and tape sizes, please refer to our Tape and Reel Packaging Specifications Brochure, [BRD8011/D](#).

13. Modified UVLO thresholds.

## RELATED PRODUCTS

Type	Part Number	Gate Drive (Note 15) (Sink/Src)	Input Threshold	Logic	Package
Dual 2 A	FAN3216T	+2.4 A / -1.6 A	TTL	Dual Inverting Channels	SOIC8
Dual 2 A	FAN3217T	+2.4 A / -1.6 A	TTL	Dual Non-Inverting Channels	SOIC8
Dual 2 A	FAN3226T	+2.4 A / -1.6 A	TTL	Dual Inverting Channels + Dual Enable	SOIC8
Dual 2 A	FAN3227C	+2.4 A / -1.6 A	CMOS	Dual Non-Inverting Channels + Dual Enable	SOIC8
Dual 2 A	FAN3227T	+2.4 A / -1.6 A	TTL	Dual Non-Inverting Channels + Dual Enable	SOIC8
Dual 2 A	FAN3229T	+2.4 A / -1.6 A	TTL	Dual Channels of Two-Input/One-Output, Pin Config.2	SOIC8
Dual 2 A	FAN3268T	+2.4 A / -1.6 A	TTL	20 V Non-Inverting Channel (NMOS) and Inverting Channel (PMOS) + Dual Enables	SOIC8
Dual 4 A	FAN3214T	+4.3 A / -2.8 A	TTL	Dual Non-Inverting Channels	SOIC8
Dual 4 A	FAD3224T	+4.3 A / -2.8 A	TTL	Dual Non-Inverting Channels + Dual Enable	SOIC8

14. Typical currents with OUTx at 6 V and  $V_{DD} = 12$  V.

15. Thresholds proportional to an externally supplied reference voltage.

# FAD3224

## REVISION HISTORY

Revision	Description of Changes	Date
0	Initial Data Sheet Release	9/2/2025
1	Removed ESD HBM row and FAD3224TUM entry from the Absolute Maximum Ratings table; updated the Electrical Characteristics (OUTPUTS) table by removing VOH, VOL, ISINK, and ISOURCE parameters and correcting "tests" to "values" in Note 11; updated Figures 18 and 19 and removed Figures 20–23 from page 9. Removed Notes 9 and 10 from the Recommended Operating Conditions and Electrical Characteristics tables (pages 4–5). Added new Notes 9 and 10 to the Absolute Maximum Ratings table (page 3), including Note 10 for the IOOUT Diode row.	4/9/2026

SOIC8  
CASE 751EB  
ISSUE A

DATE 24 AUG 2017

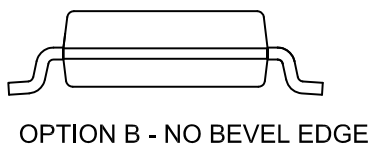
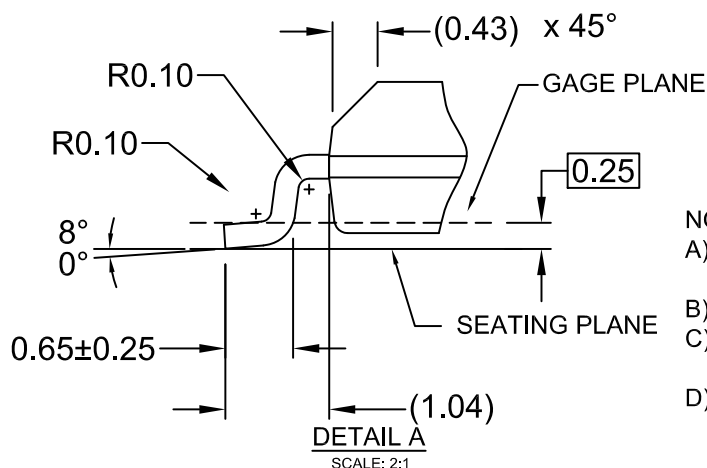
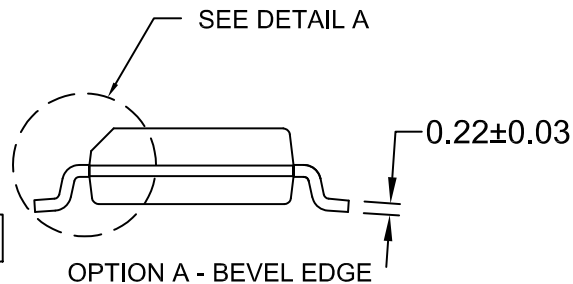
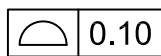
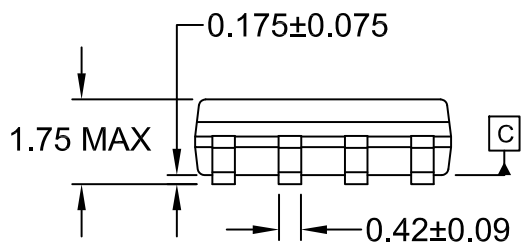
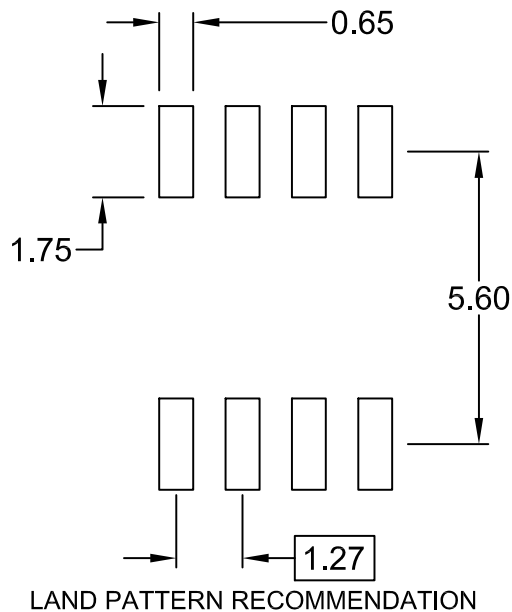
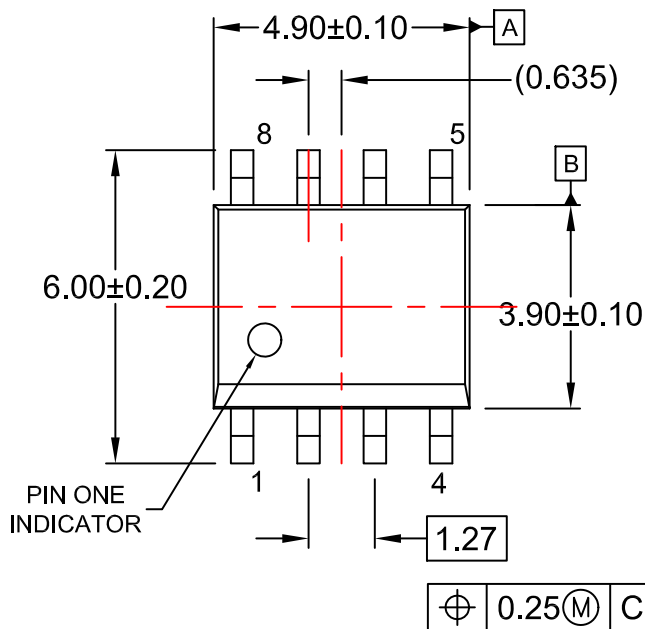

- NOTES:  
 A) THIS PACKAGE CONFORMS TO JEDEC MS-012, VARIATION AA.  
 B) ALL DIMENSIONS ARE IN MILLIMETERS.  
 C) DIMENSIONS DO NOT INCLUDE MOLD FLASH OR BURRS.  
 D) LANDPATTERN STANDARD: SOIC127P600X175-8M

DOCUMENT NUMBER:	98AON13735G	Electronic versions are uncontrolled except when accessed directly from the Document Repository. Printed versions are uncontrolled except when stamped "CONTROLLED COPY" in red.
DESCRIPTION:	SOIC8	PAGE 1 OF 1

onsemi and ONSEMI are trademarks of Semiconductor Components Industries, LLC dba onsemi or its subsidiaries in the United States and/or other countries. onsemi reserves the right to make changes without further notice to any products herein. onsemi makes no warranty, representation or guarantee regarding the suitability of its products for any particular purpose, nor does onsemi assume any liability arising out of the application or use of any product or circuit, and specifically disclaims any and all liability, including without limitation special, consequential or incidental damages. onsemi does not convey any license under its patent rights nor the rights of others.

**onsemi**, **Onsemi**, and other names, marks, and brands are registered and/or common law trademarks of Semiconductor Components Industries, LLC dba "**onsemi**" or its affiliates and/or subsidiaries in the United States and/or other countries. **onsemi** owns the rights to a number of patents, trademarks, copyrights, trade secrets, and other intellectual property. A listing of **onsemi**'s product/patent coverage may be accessed at [www.onsemi.com/site/pdf/Patent-Marking.pdf](http://www.onsemi.com/site/pdf/Patent-Marking.pdf). **onsemi** reserves the right to make changes at any time to any products or information herein, without notice. The information herein is provided "as-is" and **onsemi** makes no warranty, representation or guarantee regarding the accuracy of the information, product features, availability, functionality, or suitability of its products for any particular purpose, nor does **onsemi** assume any liability arising out of the application or use of any product or circuit, and specifically disclaims any and all liability, including without limitation special, consequential or incidental damages. Buyer is responsible for its products and applications using **onsemi** products, including compliance with all laws, regulations and safety requirements or standards, regardless of any support or applications information provided by **onsemi**. "Typical" parameters which may be provided in **onsemi** data sheets and/or specifications can and do vary in different applications and actual performance may vary over time. All operating parameters, including "Typicals" must be validated for each customer application by customer's technical experts. **onsemi** does not convey any license under any of its intellectual property rights nor the rights of others. **onsemi** products are not designed, intended, or authorized for use as a critical component in life support systems or any FDA Class 3 medical devices or medical devices with a same or similar classification in a foreign jurisdiction or any devices intended for implantation in the human body. Should Buyer purchase or use **onsemi** products for any such unintended or unauthorized application, Buyer shall indemnify and hold **onsemi** and its officers, employees, subsidiaries, affiliates, and distributors harmless against all claims, costs, damages, and expenses, and reasonable attorney fees arising out of, directly or indirectly, any claim of personal injury or death associated with such unintended or unauthorized use, even if such claim alleges that **onsemi** was negligent regarding the design or manufacture of the part. **onsemi** is an Equal Opportunity/Affirmative Action Employer. This literature is subject to all applicable copyright laws and is not for resale in any manner.

## ADDITIONAL INFORMATION

### TECHNICAL PUBLICATIONS:

Technical Library: [www.onsemi.com/design/resources/technical-documentation](http://www.onsemi.com/design/resources/technical-documentation)  
onsemi Website: [www.onsemi.com](http://www.onsemi.com)

### ONLINE SUPPORT: [www.onsemi.com/support](http://www.onsemi.com/support)

For additional information, please contact your local Sales Representative at [www.onsemi.com/support/sales](http://www.onsemi.com/support/sales)