

1-Bit Dual-Supply Level Translator

NL3V1T244, NL3V1T240, NL3V1T34

The NL3V1T244 / NL3V1T240 / NL3V1T34 are 1-bit configurable dual-supply level translators with 3-state outputs. The A- and B-ports are designed to track two different power supply rails, V_{CCA} and V_{CCB} respectively. Both supply rails are configurable from 0.9 V to 3.6 V allowing universal voltage level translation between the A- to B- ports.

The NL3V1T244 / NL3V1T34 are 1-bit level translators that allows non-inverting translations from A to B ports. The NL3V1T240 is a 1-bit level translator that allows inverting translations from A to B ports.

The output enable pin (\overline{OE}), when High, disables all the output ports by putting them in 3-state. The \overline{OE} pin is designed to track V_{CCA} . The NL3V1T34 does not have an \overline{OE} pin.

Features

- Wide V_{CCA} and V_{CCB} Operating Range: 0.9 V to 3.6 V
- Balanced Output Drive: ± 24 mA @ 3.0 V
- High-Speed w/ Balanced Propagation Delay: 2.8 ns max at 3.0 to 3.6 V
- Inputs Pins OVT to 3.6 V
- Non-preferential V_{CC} Sequencing
- Outputs at 3-State until Active V_{CC} is Reached
- Partial Power-Off Protection
- Outputs Switch to 3-State with either V_{CC} at GND
- Typical Max Data Rates:
 - 380 Mbps (≥ 1.8 -V to 3.3-V Translation)
 - 200 Mbps (≥ 1.1 -V to [1.8-V, 2.5-V, 3.3-V] Translation)
 - 150 Mbps (≥ 1.1 -V to 1.5-V Translation)
 - 100 Mbps (≥ 1.1 -V to 1.2-V Translation)
- Small Pb-Free Packaging: SC-88A, UDFN6
- -Q Suffix for Automotive and Other Applications Requiring Unique Site and Control Change Requirements; AEC-Q100 Qualified and PPAP Capable*
- These Devices are Pb-Free, Halogen Free/BFR Free and are RoHS Compliant

Typical Applications

- Mobile Phones, PDAs, Other Portable Devices
- Automotive
- Industrial

MARKING DIAGRAMS



UDFN6
MU SUFFIX
CASE 517AA

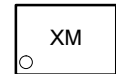

UDFN6
MU SUFFIX
CASE 517AQ



SC-88A
(SOT-353/SC-70)
DF SUFFIX
CASE 419A

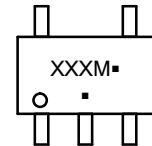

XXX = Specific Device Code
 M = Date Code
 ■ = Pb-Free Package

(Note: Microdot may be in either location)

ORDERING INFORMATION

See detailed ordering and shipping information in the package dimensions section on page 7 of this data sheet.

NL3V1T244, NL3V1T240, NL3V1T34

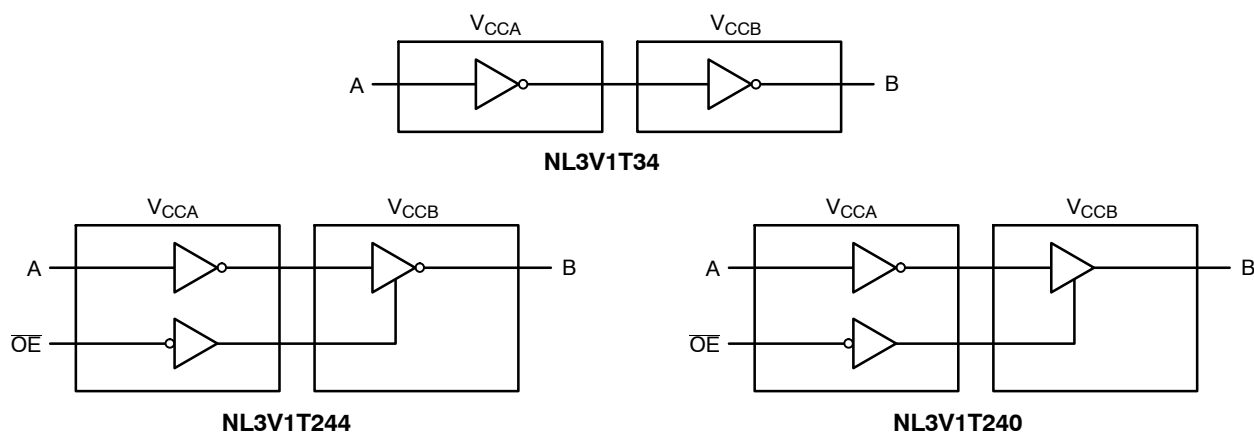

Figure 1. Logic Diagrams

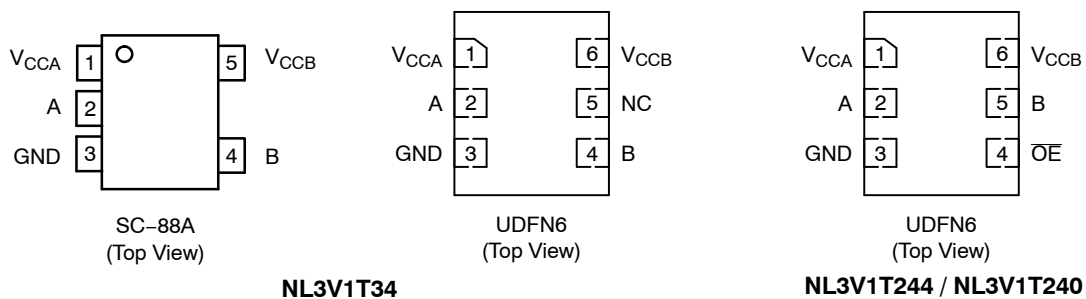

Figure 2. Pin Assignments (Top View)

FUNCTION TABLE

INPUTS		OUTPUT		
		NL3V1T34	NL3V1T244	NL3V1T240
OE	A	B	B	B
L	L	L	L	H
L	H	H	H	L
H	X	n/a	3-State	3-State

PIN NAMES

PINS	DESCRIPTION
V_{CCA}	A Port DC Supply
V_{CCB}	B Port DC Supply
GND	Ground
A	Input Port
B	Output Port
\overline{OE}	Output Enable (Not available for NL3V1T34)

Application Recommendations

During power-up and power-down, it is recommended that the \overline{OE} pin be connected to V_{CC} through pull-up resistors to ensure high impedance at the I/O ports.

NL3V1T244, NL3V1T240, NL3V1T34

MAXIMUM RATINGS

Symbol	Rating	Value	Condition	Unit
V_{CCA}, V_{CCB}	DC Supply Voltage	-0.5 to +4.3		V
V_I	DC Input Voltage	-0.5 to +4.3		V
V_O	DC Output Voltage (Power Down Mode)	-0.5 to +4.3	$V_{CCA} = V_{CCB} = 0$	V
	(3-State Mode)	-0.5 to +4.3		
	(Active Mode)	-0.5 to $V_{CCB}+0.5$		
I_{IK}	DC Input Diode Current	-50	$V_I < \text{GND}$	mA
I_{OK}	DC Output Diode Current	-50	$V_O < \text{GND}$	mA
I_O	DC Output Source/Sink Current	± 50		mA
I_{CC}	DC Supply Current Per Supply Pin	± 100		mA
I_{GND}	DC Ground Current per Ground Pin	± 100		mA
T_{STG}	Storage Temperature Range	-65 to +150		°C
θ_{JA}	Thermal Resistance (Note 1)	SC-88A	377	°C/W
		UDFN6	154	
P_D	Power Dissipation in Still Air	SC-88A	332	mW
		UDFN6	812	
MSL	Moisture Sensitivity Level		Level 1	-
F_R	Flammability Rating	Oxygen Index: 28 to 34	UL 94 V-0 @ 0.125 in	-
V_{ESD}	ESD Withstand Voltage (Note 2)	Human Body Model	2	kV
		Charged Device Model	1	
$I_{LATCHUP}$	Latchup Performance Above V_{CC} and Below GND at 25°C (Note 3)		± 100	mA

Stresses exceeding those listed in the Maximum Ratings table may damage the device. If any of these limits are exceeded, device functionality should not be assumed, damage may occur and reliability may be affected.

1. Measured with minimum pad spacing on an FR4 board, using 76 mm-by-114 mm, 2-ounce copper trace no air flow per JESD51-7.
2. HBM tested to ANSI/ESDA/JEDEC JS-001-2017. CDM tested to EIA/JESD22-C101-A. JEDEC recommends that ESD qualification to EIA/JESD22-A115A (Machine Model) be discontinued per JEDEC/JEP172A.
3. Tested to EIA/JESD78 Class II.

RECOMMENDED OPERATING CONDITIONS

Symbol	Parameter	Min	Max	Unit
V_{CCA}, V_{CCB}	Positive DC Supply Voltage	0.9	3.6	V
V_I	Input Voltage	GND	3.6	V
V_{IO}	Output Voltage (Power Down Mode)	GND	3.6	V
	(3-State Mode)	GND	3.6	
	(Active Mode)	GND	V_{CCB}	
T_A	Operating Temperature Range	-40	+125	°C
$\Delta t / \Delta V$	Input Transition Rise or Rate	0	5	nS/V

Functional operation above the stresses listed in the Recommended Operating Ranges is not implied. Extended exposure to stresses beyond the Recommended Operating Ranges limits may affect device reliability.

NL3V1T244, NL3V1T240, NL3V1T34

DC ELECTRICAL CHARACTERISTICS – INPUT VOLTAGES

Symbol	Parameter	Test Conditions	Port	V _{CCA} (V)	V _{CCB} (V)	-40 °C to +85 °C			-40 °C to +125 °C		Unit
						Min	Typ (Note 4)	Max	Min	Max	
V _{IH}	Input HIGH Voltage		OE, A	2.7 – 3.6	0.9 – 3.6	2.0	–	–	2.0	–	V
				2.3 – 2.7		1.6	–	–	1.6	–	
				1.65–1.95		0.65 V _{CCA}	–	–	0.65 V _{CCA}	–	
				1.1 – 1.6		0.7 V _{CCA}	–	–	0.7 V _{CCA}	–	
				0.9		–	0.9 V _{CCA}	–	–	–	
V _{IL}	Input LOW Voltage		OE, A	2.7 – 3.6	0.9 – 3.6	–	–	0.8	–	0.8	V
				2.3 – 2.7		–	–	0.7	–	0.7	
				1.65–1.95		–	–	0.35 V _{CCA}	–	0.35 V _{CCA}	
				1.1 – 1.6		–	–	0.3 V _{CCA}	–	0.3 V _{CCA}	
				0.9		–	0.1 V _{CCA}	–	–	–	

4. All typical values are at T_A = 25°C.

DC ELECTRICAL CHARACTERISTICS – OUTPUT VOLTAGES

Symbol	Parameter	Test Conditions	V _{CCA} (V)	V _{CCB} (V)	-40 °C to +85 °C			-40 °C to +125 °C		Unit
					Min	Typ (Note 4)	Max	Min	Max	
V _{OH}	Output HIGH Voltage	V _I = V _{IH} or V _{IL} :								V
		I _{OH} = -100 µA	0.9	0.9	–	V _{CCB} - 0.1	–	–	–	
			1.1 – 3.6	1.1 – 3.6	V _{CCB} - 0.1	–	–	V _{CCB} - 0.1	–	
		I _{OH} = -2 mA	1.1	1.1	0.85	–	–	0.85	–	
		I _{OH} = -6 mA	1.4	1.4	1.05	–	–	1.05	–	
		I _{OH} = -8 mA	1.65	1.65	1.2	–	–	1.2	–	
			2.3	2.3	1.8	–	–	1.8	–	
		I _{OH} = -12 mA	2.7	2.7	2.2	–	–	2.2	–	
			2.3	2.3	1.7	–	–	1.7	–	
I _{OH} = -18 mA	3.0	3.0	2.4	–	–	2.4	–			
I _{OH} = -24 mA	3.0	3.0	2.2	–	–	2.2	–			
V _{OL}	Output LOW Voltage	V _I = V _{IH} or V _{IL} :								V
		I _{OL} = 100 µA	0.9	0.9	–	0.1	–	–	–	
			1.1 – 3.6	1.1 – 3.6	–	–	0.1	–	0.1	
		I _{OL} = 2 mA	1.1	1.1	–	–	0.25	–	0.25	
		I _{OL} = 6 mA	1.4	1.4	–	–	0.35	–	0.35	
		I _{OL} = 8 mA	1.65	1.65	–	–	0.3	–	0.3	
			2.3	2.3	–	–	0.4	–	0.4	
		I _{OL} = 12 mA	2.7	2.7	–	–	0.4	–	0.4	
			2.3	2.3	–	–	0.4	–	0.4	
I _{OL} = 18 mA	3.0	3.0	–	–	0.4	–	0.4			
	3.0	3.0	–	–	0.4	–	0.4			
I _{OL} = 24 mA	3.0	3.0	–	–	0.55	–	0.55			

NL3V1T244, NL3V1T240, NL3V1T34

DC ELECTRICAL CHARACTERISTICS – LEAKAGE AND SUPPLY CURRENTS

Symbol	Parameter	Test Conditions	V _{CCA} (V)	V _{CCB} (V)	-40 °C to +85 °C		-40 °C to +125 °C		Unit	
					Min	Max	Min	Max		
I _I	Input Leakage Current	V _I = 3.6 V or GND	0.9 – 3.6	0.9 – 3.6	–	±1.0	–	±5.0	μA	
I _{OZ}	3-State Output Leakage	$\overline{OE} = V_{IH}$; V _O = GND to 3.6 V	3.6	3.6	–	±1.0	–	±5.0	μA	
I _{OFF}	Power-Off Leakage Current	V _I or V _O = 0 to 3.6 V	A	0	0.9 – 3.6	–	±1.0	–	±5.0	μA
			B	0.9 – 3.6	0	–	±1.0	–	±5.0	
I _{CCA}	Quiescent Supply Current	V _I = V _{CCA} or GND; I _O = 0	0.9 – 3.6	0.9 – 3.6	–	5.0	–	10	μA	
			0	0.9 – 3.6	–	–1.0	–	–5.0		
			0.9 – 3.6	0	–	5.0	–	10		
I _{CCB}	Quiescent Supply Current	V _I = V _{CCB} or GND; I _O = 0	0.9 – 3.6	0.9 – 3.6	–	5.0	–	10	μA	
			0	0.9 – 3.6	–	5.0	–	10		
			0.9 – 3.6	0	–	–1.0	–	–5.0		

NOTE: Connect ground before applying supply voltage V_{CCA} or V_{CCB}. This device is designed with the feature that the power-up sequence of V_{CCA} and V_{CCB} will not damage the IC.

AC ELECTRICAL CHARACTERISTICS (Notes 5 and 6)

Symbol	Parameter	V _{CCA} (V)	T _A = -40 °C to +85 °C					T _A = -40 °C to +125 °C					Unit
			V _{CCB} (V)					V _{CCB} (V)					
			3.3	2.5	1.8	1.5	1.2	3.3	2.5	1.8	1.5	1.2	
			Max	Max	Max	Max	Max	Max	Max	Max	Max	Max	
t _{PLH} , t _{PHL}	Propagation Delay, A to B	3.3	2.9	3.3	4.5	5.6	9.3	3.3	3.8	5.0	6.2	9.5	nS
		2.5	3.6	3.7	4.6	5.7	9.4	4.0	4.0	5.1	6.3	9.6	
		1.8	3.9	4.0	4.9	6.0	9.6	4.3	4.3	5.4	6.6	9.8	
		1.5	4.2	4.3	5.2	6.3	9.8	4.7	4.7	5.8	7.0	10.0	
		1.2	5.1	5.2	6.2	7.1	11.0	5.7	5.8	6.9	7.9	11.2	
t _{pZH} , t _{pZL}	Output Enable, OE to B	3.3	3.8	4.7	6.8	8.7	11.3	4.2	5.2	7.5	9.6	12.4	nS
		2.5	4.0	4.8	7.0	8.8	11.3	4.4	5.3	7.7	9.7	12.4	
		1.8	4.6	5.3	7.4	9.2	11.7	5.1	5.9	8.2	10.2	12.9	
		1.5	5.6	5.8	7.7	9.6	12.1	6.2	6.4	8.5	10.6	13.3	
		1.2	7.7	7.9	8.9	10.0	13.5	8.5	8.7	9.8	11.0	14.7	
t _{pHZ} , t _{pLZ}	Output Disable, OE to B	3.3	6.2	6.4	8.1	9.3	10.2	6.9	7.1	9.0	10.3	11.3	nS
		2.5	5.2	6.2	8.2	8.8	10.4	5.8	6.9	9.1	10.4	11.5	
		1.8	6.9	6.9	8.7	9.9	10.9	7.6	7.6	9.6	10.9	12.0	
		1.5	7.6	7.4	9.1	10.3	11.3	8.2	8.4	10.1	11.4	12.5	
		1.2	8.1	8.1	9.5	9.6	12.4	9.0	10.1	10.5	10.6	13.7	

5. Propagation delays defined per Figure 3.

6. These parameters are guaranteed by characterization and are not production tested.

CAPACITANCE

Symbol	Parameter	Test Conditions	Typ (Note 4)	Unit
C _{IN}	Control Pin Input Capacitance	V _{CCA} = V _{CCB} = 3.3 V, V _I = 0 V or V _{CCA}	2.5	pF
C _{I/O}	I/O Pin Input Capacitance	V _{CCA} = V _{CCB} = 3.3 V, V _I = 0 V or V _{CCA}	5.0	pF
C _{PD} (Note 7)	Power Dissipation Capacitance	V _{CCA} = V _{CCB} = 3.3 V, V _I = 0 V or V _{CCA} , f = 10 MHz	12	pF

7. C_{PD} is defined as the value of the IC's equivalent capacitance from which the operating current can be calculated from:

$$I_{CC(\text{operating})} \cong C_{PD} \times V_{CC} \times f_{IN} \times N_{SW} \text{ where } I_{CC} = I_{CCA} + I_{CCB} \text{ and } N_{SW} = \text{total number of outputs switching.}$$

NL3V1T244, NL3V1T240, NL3V1T34

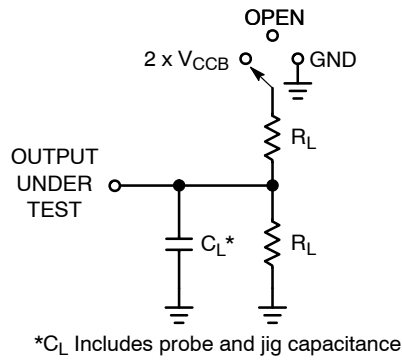

Figure 3. AC Test Circuit

Test	Switch	C _L	R _L
t _{PLH} , t _{PZH}	OPEN	15 pF	2 kΩ
t _{PLZ} , t _{PZL}	2 x V _{CCB}		
t _{PHZ} , t _{PZH}	GND		

C_L includes probe and jig capacitance
Pulse generator Z_O = 50 Ω
Input f = 1.0 MHz; t_W = 500 ns

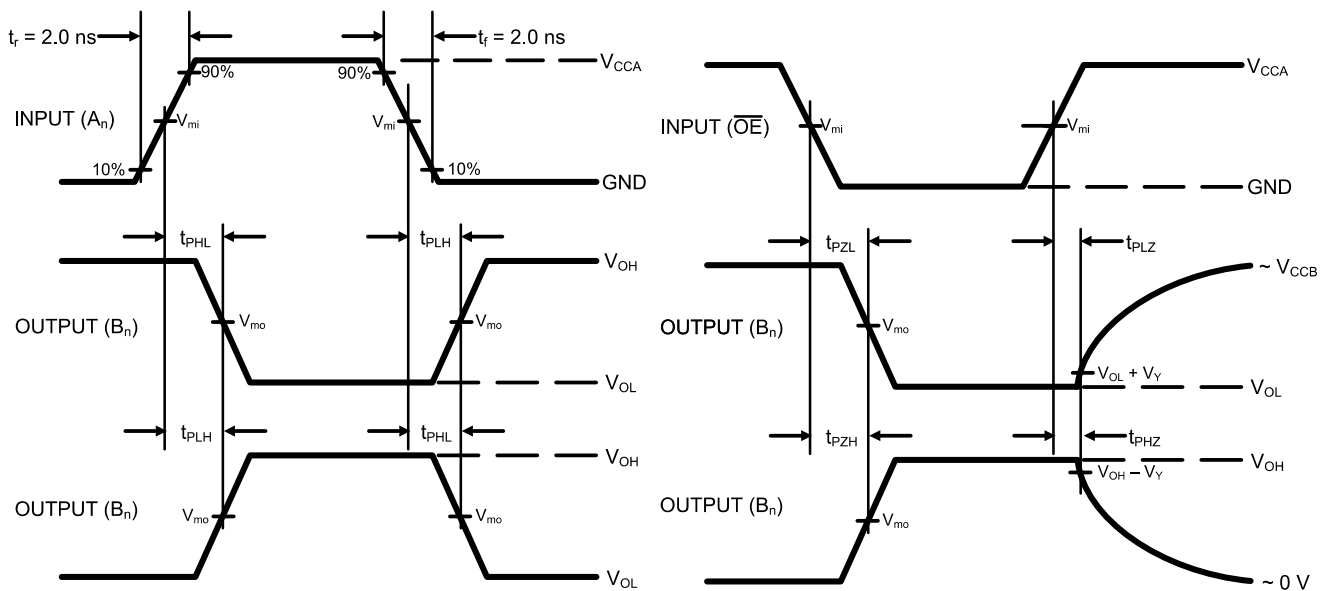

Figure 4. AC Waveforms

Symbol	V _{CC}				
	3.0 V – 3.6 V	2.3 V – 2.7 V	1.65 V – 1.95 V	1.4 V – 1.6 V	1.1 V – 1.3 V
V _{mi}	V _{CCA} /2	V _{CCA} /2	V _{CCA} /2	V _{CCA} /2	V _{CCA} /2
V _{mo}	V _{CCB} /2	V _{CCB} /2	V _{CCB} /2	V _{CCB} /2	V _{CCB} /2
V _Y	0.3 V	0.15 V	0.15 V	0.1 V	0.1 V

NL3V1T244, NL3V1T240, NL3V1T34

ORDERING INFORMATION

Device	Marking	Package	Pin 1 Quadrant	Shipping [†]
NL3V1T34DFT2G	AFR	SC-88A	3	3000 Units / Tape & Reel
NL3V1T34DFT2G-Q*	AFR	SC-88A	3	3000 Units / Tape & Reel
NL3V1T34MU1TAG	AD	UDFN6, 1.45x1, 0.5P	1	3000 Units / Tape & Reel
NL3V1T34MU1TCG	AD	UDFN6, 1.45x1, 0.5P	3	3000 Units / Tape & Reel
NL3V1T34MU2TBG	EQ	UDFN6, 1.2x1, 0.4P	2	3000 Units / Tape & Reel
NL3V1T244MU2TBG	AQ	UDFN6, 1.2x1, 0.4P	2	3000 Units / Tape & Reel
NL3V1T244MU2TBG-Q*	AQ	UDFN6, 1.2x1, 0.4P	2	3000 Units / Tape & Reel
NL3V1T240MU2TBG	A3	UDFN6, 1.2x1, 0.4P	2	3000 Units / Tape & Reel

[†] For information on tape and reel specifications, including part orientation and tape sizes, please refer to our Tape and Reel Packaging Specifications Brochure, [BRD8011/D](#).

* -Q Suffix for Automotive and Other Applications Requiring Unique Site and Control Change Requirements; AEC-Q100 Qualified and PPAP Capable.

Pin 1 Orientation in Tape and Reel

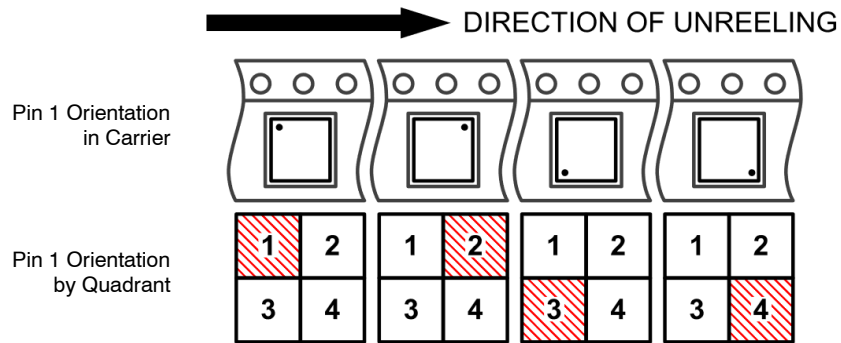

NL3V1T244, NL3V1T240, NL3V1T34

REVISION HISTORY

Revision	Description of Changes	Date
0	Initial document version release.	8/20/2025



SCALE 2:1

SC-88A (SC-70-5/SOT-353)
CASE 419A-02
ISSUE M

DATE 11 APR 2023

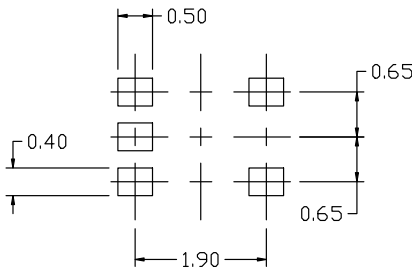
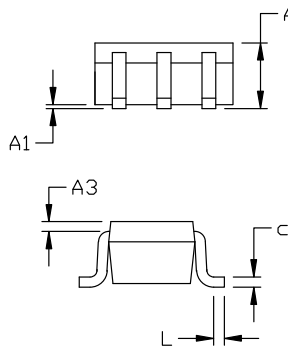
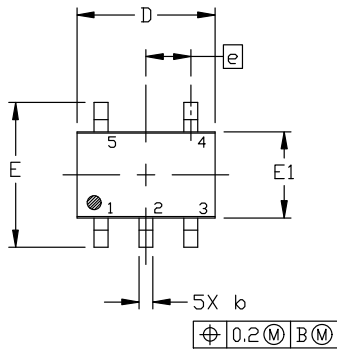

RECOMMENDED MOUNTING FOOTPRINT

* For additional information on our Pb-Free strategy and soldering details, please download the ON Semiconductor Soldering and Mounting Techniques Reference Manual, SOLDERM/D.

NOTES:

1. DIMENSIONING AND TOLERANCING PER ANSI Y14.5M, 1982.
2. CONTROLLING DIMENSION: MILLIMETERS
3. 419A-01 OBSOLETE. NEW STANDARD 419A-02
4. DIMENSIONS D AND E1 DO NOT INCLUDE MOLD FLASH, PROTRUSIONS, OR GATE BURRS. MOLD FLASH, PROTRUSIONS, OR GATE BURRS SHALL NOT EXCEED 0.1016MM PER SIDE.

DIM	MILLIMETERS		
	MIN.	NOM.	MAX.
A	0.80	0.95	1.10
A1	---	---	0.10
A3	0.20 REF		
b	0.10	0.20	0.30
c	0.10	---	0.25
D	1.80	2.00	2.20
E	2.00	2.10	2.20
E1	1.15	1.25	1.35
e	0.65 BSC		
L	0.10	0.15	0.30

GENERIC MARKING DIAGRAM*

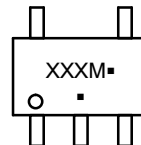

*This information is generic. Please refer to device data sheet for actual part marking. Pb-Free indicator, "G" or microdot "▪", may or may not be present. Some products may not follow the Generic Marking.

XXX = Specific Device Code
M = Date Code
▪ = Pb-Free Package

(Note: Microdot may be in either location)

STYLE 1:

- PIN 1. BASE
- 2. EMITTER
- 3. BASE
- 4. COLLECTOR
- 5. COLLECTOR

STYLE 2:

- PIN 1. ANODE
- 2. EMITTER
- 3. BASE
- 4. COLLECTOR
- 5. CATHODE

STYLE 3:

- PIN 1. ANODE 1
- 2. N/C
- 3. ANODE 2
- 4. CATHODE 2
- 5. CATHODE 1

STYLE 4:

- PIN 1. SOURCE 1
- 2. DRAIN 1/2
- 3. SOURCE 1
- 4. GATE 1
- 5. GATE 2

STYLE 5:

- PIN 1. CATHODE
- 2. COMMON ANODE
- 3. CATHODE 2
- 4. CATHODE 3
- 5. CATHODE 4

STYLE 6:

- PIN 1. EMITTER 2
- 2. BASE 2
- 3. EMITTER 1
- 4. COLLECTOR
- 5. COLLECTOR 2/BASE 1

STYLE 7:

- PIN 1. BASE
- 2. EMITTER
- 3. BASE
- 4. COLLECTOR
- 5. COLLECTOR

STYLE 8:

- PIN 1. CATHODE
- 2. COLLECTOR
- 3. N/C
- 4. BASE
- 5. EMITTER

STYLE 9:

- PIN 1. ANODE
- 2. CATHODE
- 3. ANODE
- 4. ANODE
- 5. ANODE

Note: Please refer to datasheet for style callout. If style type is not called out in the datasheet refer to the device datasheet pinout or pin assignment.

DOCUMENT NUMBER:	98ASB42984B	Electronic versions are uncontrolled except when accessed directly from the Document Repository. Printed versions are uncontrolled except when stamped "CONTROLLED COPY" in red.
DESCRIPTION:	SC-88A (SC-70-5/SOT-353)	PAGE 1 OF 1

onsemi and onsemi are trademarks of Semiconductor Components Industries, LLC dba onsemi or its subsidiaries in the United States and/or other countries. onsemi reserves the right to make changes without further notice to any products herein. onsemi makes no warranty, representation or guarantee regarding the suitability of its products for any particular purpose, nor does onsemi assume any liability arising out of the application or use of any product or circuit, and specifically disclaims any and all liability, including without limitation special, consequential or incidental damages. onsemi does not convey any license under its patent rights nor the rights of others.

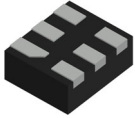

UDFN6, 1.20x1.00x0.50, 0.40P
CASE 517AA
ISSUE E

DATE 09 MAY 2025

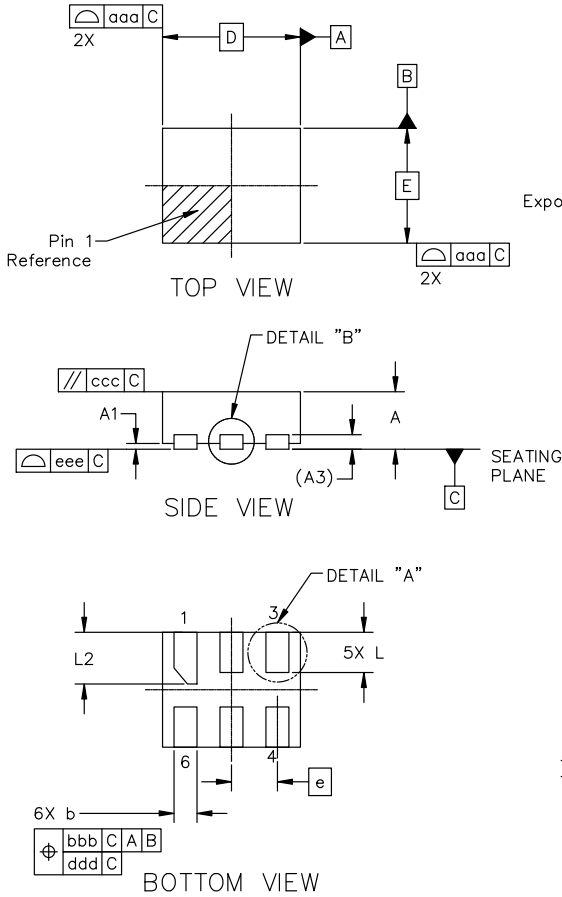

- NOTES:
1. DIMENSIONING AND TOLERANCING AS PER ASME Y14.5M, 2018.
 2. CONTROLLING DIMENSION: MILLIMETERS.
 3. DIMENSION b APPLIES TO PLATED TERMINAL AND IS MEASURED BETWEEN 0.25 AND 0.30mm FROM TERMINAL.
 4. COPLANARITY APPLIES TO THE EXPOSED PAD AS WELL AS THE TERMINALS.

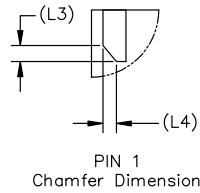
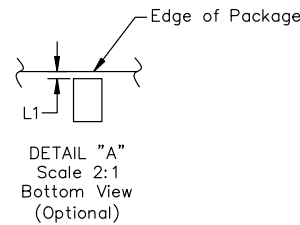
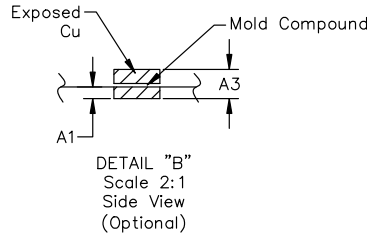

MILLIMETERS			
DIM	MIN	NOM	MAX
A	0.45	0.50	0.55
A1	0.00	---	0.05
A3	0.127 REF		
b	0.15	0.20	0.25
D	1.20 BSC		
E	1.00 BSC		
e	0.40 BSC		
L	0.30	0.35	0.40
L1	0.00	---	0.15
L2	0.40	0.45	0.50
L3	0.14 REF		
L4	0.116 REF		
TOLERANCE FORM & POSITION			
aaa	0.10		
bbb	0.10		
ccc	0.10		
ddd	0.05		
eee	0.08		

GENERIC MARKING DIAGRAM*



XX = Specific Device Code
M = Date Code

*This information is generic. Please refer to device data sheet for actual part marking. Pb-Free indicator, "G" or microdot "•", may or may not be present. Some products may not follow the Generic Marking.

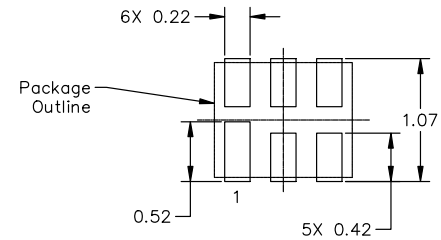

RECOMMENDED MOUNTING FOOTPRINT

*For additional information on our Pb-Free strategy and soldering details, please download the onsemi Soldering and Mounting Techniques Reference Manual, SOLDERRM/D.

DOCUMENT NUMBER:	98AON22068D	Electronic versions are uncontrolled except when accessed directly from the Document Repository. Printed versions are uncontrolled except when stamped "CONTROLLED COPY" in red.
DESCRIPTION:	UDFN6, 1.20x1.00x0.50, 0.40P	PAGE 1 OF 1

onsemi and ONSEMI are trademarks of Semiconductor Components Industries, LLC dba onsemi or its subsidiaries in the United States and/or other countries. onsemi reserves the right to make changes without further notice to any products herein. onsemi makes no warranty, representation or guarantee regarding the suitability of its products for any particular purpose, nor does onsemi assume any liability arising out of the application or use of any product or circuit, and specifically disclaims any and all liability, including without limitation special, consequential or incidental damages. onsemi does not convey any license under its patent rights nor the rights of others.



SCALE 4:1

UDFN6, 1.45x1.0, 0.5P
CASE 517AQ
ISSUE O

DATE 15 MAY 2008

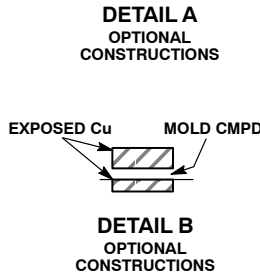
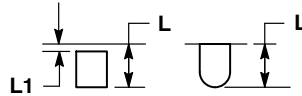
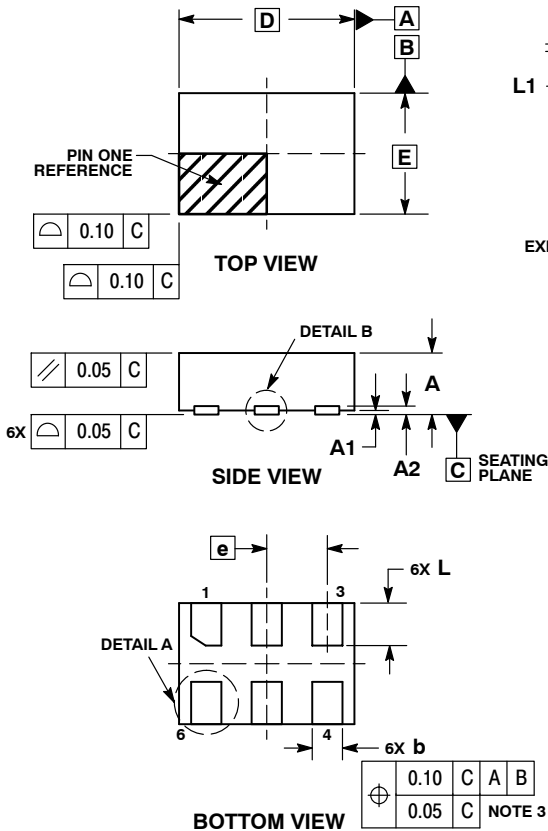

NOTES:

1. DIMENSIONING AND TOLERANCING PER ASME Y14.5M, 1994.
2. CONTROLLING DIMENSION: MILLIMETERS.
3. DIMENSION b APPLIES TO PLATED TERMINAL AND IS MEASURED BETWEEN 0.15 AND 0.30 mm FROM THE TERMINAL TIP.

MILLIMETERS		
DIM	MIN	MAX
A	0.45	0.55
A1	0.00	0.05
A2	0.07	REF
b	0.20	0.30
D	1.45	BSC
E	1.00	BSC
e	0.50	BSC
L	0.30	0.40
L1	---	0.15

MOUNTING FOOTPRINT

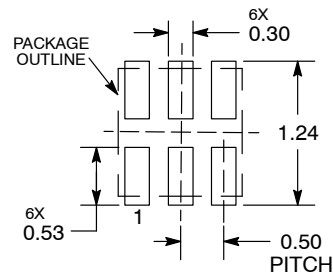

DIMENSIONS: MILLIMETERS

*For additional information on our Pb-Free strategy and soldering details, please download the **onsemi** Soldering and Mounting Techniques Reference Manual, SOLDERRM/D.

GENERIC
MARKING DIAGRAM*



X = Specific Device Code

M = Date Code

*This information is generic. Please refer to device data sheet for actual part marking. Pb-Free indicator, "G" or microdot "▪", may or may not be present.

DOCUMENT NUMBER:	98AON30313E	Electronic versions are uncontrolled except when accessed directly from the Document Repository. Printed versions are uncontrolled except when stamped "CONTROLLED COPY" in red.
DESCRIPTION:	UDFN6, 1.45x1.0, 0.5P	PAGE 1 OF 1

onsemi and onsemi are trademarks of Semiconductor Components Industries, LLC dba onsemi or its subsidiaries in the United States and/or other countries. onsemi reserves the right to make changes without further notice to any products herein. onsemi makes no warranty, representation or guarantee regarding the suitability of its products for any particular purpose, nor does onsemi assume any liability arising out of the application or use of any product or circuit, and specifically disclaims any and all liability, including without limitation special, consequential or incidental damages. onsemi does not convey any license under its patent rights nor the rights of others.

onsemi, **Onsemi**, and other names, marks, and brands are registered and/or common law trademarks of Semiconductor Components Industries, LLC dba "**onsemi**" or its affiliates and/or subsidiaries in the United States and/or other countries. **onsemi** owns the rights to a number of patents, trademarks, copyrights, trade secrets, and other intellectual property. A listing of **onsemi**'s product/patent coverage may be accessed at www.onsemi.com/site/pdf/Patent-Marking.pdf. **onsemi** reserves the right to make changes at any time to any products or information herein, without notice. The information herein is provided "as-is" and **onsemi** makes no warranty, representation or guarantee regarding the accuracy of the information, product features, availability, functionality, or suitability of its products for any particular purpose, nor does **onsemi** assume any liability arising out of the application or use of any product or circuit, and specifically disclaims any and all liability, including without limitation special, consequential or incidental damages. Buyer is responsible for its products and applications using **onsemi** products, including compliance with all laws, regulations and safety requirements or standards, regardless of any support or applications information provided by **onsemi**. "Typical" parameters which may be provided in **onsemi** data sheets and/or specifications can and do vary in different applications and actual performance may vary over time. All operating parameters, including "Typicals" must be validated for each customer application by customer's technical experts. **onsemi** does not convey any license under any of its intellectual property rights nor the rights of others. **onsemi** products are not designed, intended, or authorized for use as a critical component in life support systems or any FDA Class 3 medical devices or medical devices with a same or similar classification in a foreign jurisdiction or any devices intended for implantation in the human body. Should Buyer purchase or use **onsemi** products for any such unintended or unauthorized application, Buyer shall indemnify and hold **onsemi** and its officers, employees, subsidiaries, affiliates, and distributors harmless against all claims, costs, damages, and expenses, and reasonable attorney fees arising out of, directly or indirectly, any claim of personal injury or death associated with such unintended or unauthorized use, even if such claim alleges that **onsemi** was negligent regarding the design or manufacture of the part. **onsemi** is an Equal Opportunity/Affirmative Action Employer. This literature is subject to all applicable copyright laws and is not for resale in any manner.

ADDITIONAL INFORMATION

TECHNICAL PUBLICATIONS:

Technical Library: www.onsemi.com/design/resources/technical-documentation
onsemi Website: www.onsemi.com

ONLINE SUPPORT: www.onsemi.com/support

For additional information, please contact your local Sales Representative at www.onsemi.com/support/sales

