

2-Bit 24 Mbps Configurable Dual-Supply Autosense Level Translator

NL5X4002

The NL5X4002 is a 2-bit configurable dual-supply bidirectional auto sensing translator that does not require directional control pins. The A and B ports are designed to track two different power supply rails, V_{CCA} and V_{CCB} respectively. Both the V_{CCA} and V_{CCB} supply rails are configurable from 1.65 V to 5.5 V. This allows voltage logic signals on the V_{CCA} side to be translated into lower, higher or equal value voltage logic signals on the V_{CCB} side, and vice-versa.

The NL5X4002 translator has integrated 10 k Ω pullup resistors on the I/O lines. The integrated pullup resistors are used to pull the I/O lines up to either V_{CCA} or V_{CCB} .

These devices are excellent matches for open-drain applications such as the I²C communication bus.

Features

- Wide V_{CCA} , V_{CCB} Operating Range: 1.65 V to 5.5 V
- V_{CCA} and V_{CCB} are independent
 - V_{CCA} may be greater than, equal to, or less than V_{CCB}
- High-Speed w/ 24 Mbps Guaranteed Data Rate
- Low Bit-to-Bit skew
- Overvoltage Tolerant Enable and I/O Pins
- Non-preferential Power-Up Sequencing
- Integrated 10 k Ω Pullup Resistors (NL5X4002)
- Available packaging: SOIC-8, Micro8, UDFN8
- -Q Suffix for Automotive and Other Applications Requiring Unique Site and Control Change Requirements; AEC-Q101 Qualified and PPAP Capable
- These Devices are Pb-Free, Halogen Free/BFR Free and are RoHS Compliant

Typical Applications

- I²C, SMBus, PMBus
- Low Voltage ASIC Level Translation
- Mobile Phones, PDAs, Cameras

SOIC-8 NB
CASE 751

Micro8
CASE 846A

UDFN8
CASE 517AJ

MARKING DIAGRAMS

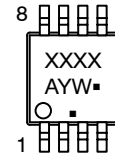
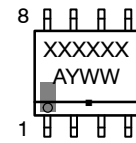

- XXXXXX = Specific Device Code
- A = Assembly Location
- L = Wafer Lot
- Y = Year
- W = Work Week
- = Pb-Free Package

(Note: Microdot may be in either location)

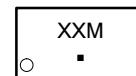

- XX = Specific Device Code
- M = Date Code
- = Pb-Free Package

ORDERING INFORMATION

See detailed ordering and shipping information on page 12 of this data sheet.

NL5X4002

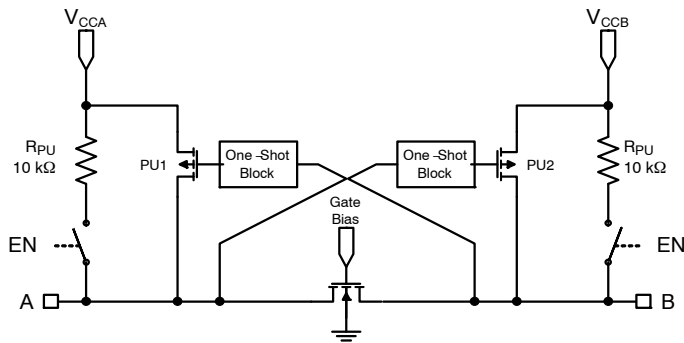

Figure 1. NL5X4002 Block Diagram (1 I/O Line)

PIN ASSIGNMENTS

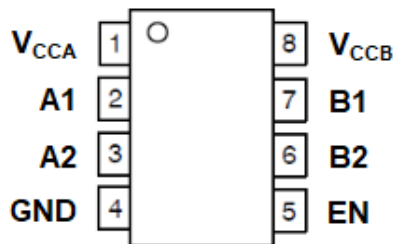

Figure 2. SOIC-8/Micro8

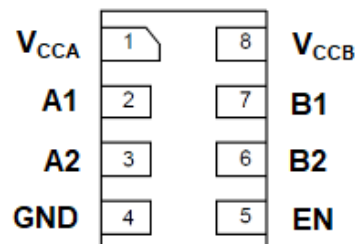

Figure 3. UDFN8

PIN DESCRIPTIONS

Pin	Description
VCCA	A-Port Supply Voltage
VCCB	B-Port Supply Voltage
GND	Ground
An	A-Port, Referenced to VCCA
Bn	B-Port, Referenced to VCCB
EN	Enable, Referenced to VCCA

FUNCTION TABLE

EN	Operating Mode
L	An and Bn at Hi-Z
H	An and Bn Connected

NL5X4002

MAXIMUM RATINGS

Symbol	Parameter	Condition	Value	Unit
V _{CCA}	A-side DC Supply Voltage		-0.5 to +6.5	V
V _{CCB}	B-side DC Supply Voltage		-0.5 to +6.5	V
V _{EN}	EN Pin Input Voltage		-0.5 to +6.5	V
V _{IO}	Input/Output Voltage	Active Mode (A-Port) Active Mode (B-Port) Tri-State Mode (EN = L) Power Down Mode (V _{CCA} and/or V _{CCB} = 0 V)	-0.5 to V _{CCA} +0.5 -0.5 to V _{CCB} +0.5 -0.5 to +6.5 -0.5 to +6.5	V
I _{IOK}	Input/Output Clamp Current	V _{IO} < GND	-50	mA
I _{IO_SC}	Input/Output Short Circuit Current	Continuous	±50	mA
I _{CCA}	DC Supply Current Through V _{CCA}		±100	mA
I _{CCB}	DC Supply Current Through V _{CCB}		±100	mA
I _{GND}	DC Ground Current Through Ground Pin		±100	mA
T _{STG}	Storage Temperature		-65 to +150	°C
θ _{JA}	Thermal Resistance (Note 1)	SOIC-8 Micro8 UDFN8	134 167 231	°C/W
P _D	Power Dissipation in Still Air	SOIC-8 Micro8 UDFN8	935 748 541	mW
MSL	Moisture Sensitivity		Level 1	
F _R	Flammability Rating	Oxygen Index: 28 to 34	UL 94 V-0 @ 0.125 in	
V _{ESD}	ESD Withstand Voltage (Note 2)	Human Body Model Charged Device Model	Bn to GND or V _{CCB} All Pins 8000 2000 1000	V
I _{LATCHUP}	Latchup Performance	Above V _{CC} and Below GND (Note 3)	±100	mA

Stresses exceeding those listed in the Maximum Ratings table may damage the device. If any of these limits are exceeded, device functionality should not be assumed, damage may occur and reliability may be affected.

1. Measured with minimum pad spacing on an FR4 board, using 10 mm-by-1 inch, 2 ounce copper trace no air flow per JESD51-7.
2. HBM tested to ANSI/ESDA/JEDEC JS-001-2017. CDM tested to EIA/JESD22-C101-F. JEDEC recommends that ESD qualification to EIA/JESD22-A115-A (Machine Model) be discontinued per JEDEC/JEP172A.
3. Tested to EIA/JESD78 Class II.

RECOMMENDED OPERATING CONDITIONS

Symbol	Parameter	Min	Max	Unit
V _{CCA}	A-Port Supply Voltage	1.65	5.5	V
V _{CCB}	B-Port Supply Voltage	1.65	5.5	V
V _{EN}	EN Pin Input Voltage	GND	5.5	V
V _{IO}	Input/Output Voltage	Active Mode (A-Port) Active Mode (B-Port) Tri-State Mode (EN = L) Power Down Mode (V _{CCA} and/or V _{CCB} = 0 V)	GND GND GND GND	V _{CCA} V _{CCB} 5.5 5.5
T _A	Operating Temperature Range	-40	+125	°C
Δt/ΔV	Input Transition Rise or Fall Rate, V _{IO} from 30% to 70% of V _{CCA} /V _{CCB}	0	10	nS/V

Functional operation above the stresses listed in the Recommended Operating Ranges is not implied. Extended exposure to stresses beyond the Recommended Operating Ranges limits may affect device reliability.

NL5X4002

DC ELECTRICAL CHARACTERISTICS ($V_{CCA} = 1.65\text{ V to }5.5\text{ V}$, $V_{CCB} = 1.65\text{ V to }5.5\text{ V}$, unless otherwise specified)
(Notes 4 and 5)

Symbol	Parameter	Test Conditions	-40 °C to +125 °C			Unit
			Min	Typ	Max	
V_{IHA}	V_{CCA} Input HIGH Voltage		$V_{CCA} - 0.4$	-	-	V
V_{ILA}	V_{CCA} Input LOW Voltage		-	-	0.15	V
V_{IHB}	V_{CCB} Input HIGH Voltage		$V_{CCB} - 0.4$	-	-	V
V_{ILB}	V_{CCB} Input LOW Voltage		-	-	0.15	V
V_{IH}	EN Pin Input HIGH Voltage		$0.65 * V_{CCA}$	-	-	V
V_{IL}	EN Pin Input LOW Voltage		-	-	$0.35 * V_{CCA}$	V
V_{OHA}	V_{CCA} Output HIGH Voltage	A Port source current = -20 μ A	$2/3 * V_{CCA}$	-	-	V
V_{OLA}	V_{CCA} Output LOW Voltage	A Port sink current = 1 mA	-	-	0.4	V
V_{OHB}	V_{CCB} Output HIGH Voltage	B Port source current = -20 μ A	$2/3 * V_{CCB}$	-	-	V
V_{OLB}	V_{CCB} Output LOW Voltage	B Port sink current = 1 mA	-	-	0.4	V
I_{QVCCA}	V_{CCA} Supply Current	A and B unconnected, $V_{EN} = V_{CCA}$	-	0.5	5.0	μ A
		$V_{CCA} = 5.5\text{ V}$, $V_{CCB} = 0\text{ V}$	-	-	-1.5	
		$V_{CCA} = 0\text{ V}$, $V_{CCB} = 5.5\text{ V}$	-	-	1.5	
I_{QVCCB}	V_{CCB} Supply Current	A and B unconnected, $V_{EN} = V_{CCA}$	-	0.5	5.0	μ A
		$V_{CCA} = 5.5\text{ V}$, $V_{CCB} = 0\text{ V}$	-	-	1.5	
		$V_{CCA} = 0\text{ V}$, $V_{CCB} = 5.5\text{ V}$	-	-	-1.5	
I_{Z-VCCA}	V_{CCA} Tristate Output Mode Supply Current	A and B unconnected, $V_{EN} = \text{GND}$	-	0.1	5.0	μ A
I_{Z-VCCB}	V_{CCB} Tristate Output Mode Supply Current	A and B unconnected, $V_{EN} = \text{GND}$	-	0.1	5.0	μ A
I_I	EN Pin Input Leakage Current		-	-	1.0	μ A
I_{OFF}	Power-Off Leakage Current	$V_{CCA} = 0\text{ V to }5.5\text{ V}$; $V_{CCB} = 0\text{ V}$; A = 0 V to 5.5 V	-	-	2.0	μ A
		$V_{CCA} = 0\text{ V}$; $V_{CCB} = 0\text{ to }5.5\text{ V}$; A = 0 to 5.5 V	-	-	2.0	
		$V_{CCA} = 0\text{ to }5.5\text{ V}$; $V_{CCB} = 0\text{ V}$; B = 0 to 5.5 V	-	-	2.0	
		$V_{CCA} = 0\text{ V}$; $V_{CCB} = 0\text{ to }5.5\text{ V}$; B = 0 to 5.5 V	-	-	2.0	
I_{OZ}	I/O Tristate Output Mode Leakage Current		-	0.1	2.0	μ A
R_{PU}	Pull-Up Resistors, A and B		-	10	-	k Ω

Product parametric performance is indicated in the Electrical Characteristics for the listed test conditions, unless otherwise noted. Product performance may not be indicated by the Electrical Characteristics if operated under different conditions.

4. Typical values are for $V_{CCA} = +1.8\text{ V}$, $V_{CCB} = +3.3\text{ V}$ and $T_A = +25\text{ }^\circ\text{C}$.

5. All units are production tested at $T_A = +25\text{ }^\circ\text{C}$. Limits over the operating temperature range are guaranteed by design.

NL5X4002

TIMING CHARACTERISTICS – RAIL-TO-RAIL DRIVING CONFIGURATION

(Test circuits of Figures 4, 5, 8, 9, 10 and 11, $C_{LOAD} = 15$ pF, driver output impedance $\leq 50 \Omega$, $R_{LOAD} = 1$ M Ω , unless otherwise specified. (Notes 6, 7 and 8))

Symbol	Parameter	Conditions	-40 °C to +125 °C			Unit
			Min	Typ	Max	

$V_{CCA} = 1.65$ V, $V_{CCB} = 1.65$ V

t_{RB}	B Port Rise Time			9	32	ns
t_{FB}	B Port Fall Time			11	20	ns
t_{RA}	A Port Rise Time			20	30	ns
t_{FA}	A Port Fall Time			10	13	ns
t_{PDAB}	Propagation Delay (A to B)			7	16	ns
t_{PDBA}	Propagation Delay (B to A)			12	15	ns
t_{EN}	Enable Time				125	ns
t_{DIS}	Disable Time				260	ns
t_{SKEW}	Skew				2	ns
MDR	Maximum Data Rate		15			Mbps

$V_{CCA} = 1.65$ V, $V_{CCB} = 5.5$ V

t_{RB}	B Port Rise Time			9	12	ns
t_{FB}	B Port Fall Time			17	30	ns
t_{RA}	A Port Rise Time			2	4	ns
t_{FA}	A Port Fall Time			3	7	ns
t_{PDAB}	Propagation Delay (A to B)			14	24	ns
t_{PDBA}	Propagation Delay (B to A)			3	5	ns
t_{EN}	Enable Time				125	ns
t_{DIS}	Disable Time				260	ns
t_{SKEW}	Skew				2	ns
MDR	Maximum Data Rate		24			Mbps

$V_{CCA} = 1.8$ V, $V_{CCB} = 2.8$ V

t_{RB}	B Port Rise Time			11	18	ns
t_{FB}	B Port Fall Time			10	15	ns
t_{RA}	A Port Rise Time			12	15	ns
t_{FA}	A Port Fall Time			5	8	ns
t_{PDAB}	Propagation Delay (A to B)			7	10	ns
t_{PDBA}	Propagation Delay (B to A)			5	9	ns
t_{EN}	Enable Time				125	ns
t_{DIS}	Disable Time				260	ns
t_{SKEW}	Skew				2	ns
MDR	Maximum Data Rate		24			Mbps

$V_{CCA} = 2.5$ V, $V_{CCB} = 3.6$ V

t_{RB}	B Port Rise Time			8	12	ns
t_{FB}	B Port Fall Time			8	12	ns
t_{RA}	A Port Rise Time			7	10	ns
t_{FA}	A Port Fall Time			5	7	ns
t_{PDAB}	Propagation Delay (A to B)			7	10	ns

NL5X4002

TIMING CHARACTERISTICS – RAIL-TO-RAIL DRIVING CONFIGURATION (continued)

(Test circuits of Figures 4, 5, 8, 9, 10 and 11, $C_{LOAD} = 15$ pF, driver output impedance $\leq 50 \Omega$, $R_{LOAD} = 1$ M Ω , unless otherwise specified. (Notes 6, 7 and 8))

Symbol	Parameter	Conditions	-40 °C to +125 °C			Unit
			Min	Typ	Max	

V_{CCA} = 2.5 V, V_{CCB} = 3.6 V

t _{PDBA}	Propagation Delay (B to A)			5	8	ns
t _{EN}	Enable Time				125	ns
t _{DIS}	Disable Time				260	ns
t _{SKEW}	Skew				2	ns
MDR	Maximum Data Rate		24			Mbps

V_{CCA} = 2.8 V, V_{CCB} = 1.8 V

t _{RB}	B Port Rise Time			13	20	ns
t _{FB}	B Port Fall Time			7	10	ns
t _{RA}	A Port Rise Time			8	13	ns
t _{FA}	A Port Fall Time			9	15	ns
t _{PDAB}	Propagation Delay (A to B)			6	9	ns
t _{PDBA}	Propagation Delay (B to A)			7	12	ns
t _{EN}	Enable Time				125	ns
t _{DIS}	Disable Time				260	ns
t _{SKEW}	Skew				2	ns
MDR	Maximum Data Rate		24			Mbps

V_{CCA} = 3.6 V, V_{CCB} = 2.5 V

t _{RB}	B Port Rise Time			9	12	ns
t _{FB}	B Port Fall Time			6	9	ns
t _{RA}	A Port Rise Time			6	12	ns
t _{FA}	A Port Fall Time			7	12	ns
t _{PDAB}	Propagation Delay (A to B)			5	7	ns
t _{PDBA}	Propagation Delay (B to A)			6	9	ns
t _{EN}	Enable Time				125	ns
t _{DIS}	Disable Time				260	ns
t _{SKEW}	Skew				2	ns
MDR	Maximum Data Rate		24			Mbps

V_{CCA} = 5.5 V, V_{CCB} = 1.65 V

t _{RB}	B Port Rise Time			13	20	ns
t _{FB}	B Port Fall Time			6	9	ns
t _{RA}	A Port Rise Time			8	10	ns
t _{FA}	A Port Fall Time			20	27	ns
t _{PDAB}	Propagation Delay (A to B)			5	8	ns
t _{PDBA}	Propagation Delay (B to A)			14	24	ns
t _{EN}	Enable Time				125	ns
t _{DIS}	Disable Time				260	ns
t _{SKEW}	Skew				2	ns
MDR	Maximum Data Rate		24			Mbps

NL5X4002

TIMING CHARACTERISTICS – RAIL-TO-RAIL DRIVING CONFIGURATION (continued)

(Test circuits of Figures 4, 5, 8, 9, 10 and 11, $C_{LOAD} = 15 \text{ pF}$, driver output impedance $\leq 50 \Omega$, $R_{LOAD} = 1 \text{ M}\Omega$, unless otherwise specified. (Notes 6, 7 and 8))

Symbol	Parameter	Conditions	-40 °C to +125 °C			Unit
			Min	Typ	Max	
$V_{CCA} = 5.5 \text{ V}$, $V_{CCB} = 5.5 \text{ V}$						
t_{RB}	B Port Rise Time			5	7	ns
t_{FB}	B Port Fall Time			6	8	ns
t_{RA}	A Port Rise Time			5	7	ns
t_{FA}	A Port Fall Time			4	7	ns
t_{PDAB}	Propagation Delay (A to B)			4	6	ns
t_{PDBA}	Propagation Delay (B to A)			4	6	ns
t_{EN}	Enable Time				125	ns
t_{DIS}	Disable Time				260	ns
t_{SKEW}	Skew				2	ns
MDR	Maximum Data Rate		24			Mbps

NL5X4002

TIMING CHARACTERISTICS – OPEN DRAIN DRIVING CONFIGURATION

(Test circuits of Figures 6, 7, 8, 9, 10 and 11, $C_{LOAD} = 15$ pF, driver output impedance $\leq 50 \Omega$, $R_{LOAD} = 1$ M Ω , unless otherwise specified. (Notes 6, 7 and 8))

Symbol	Parameter	Conditions	-40 °C to +125 °C			Unit
			Min	Typ	Max	

$V_{CCA} = 1.65$ V, $V_{CCB} = 5.5$ V

t_{RB}	B Port Rise Time			8	40	ns
t_{FB}	B Port Fall Time			20	30	ns
t_{RA}	A Port Rise Time			80	110	ns
t_{FA}	A Port Fall Time			3	7	ns
t_{PDAB}	Propagation Delay (A to B)			27	45	ns
t_{PDBA}	Propagation Delay (B to A)			9	17	ns
t_{EN}	Enable Time				125	ns
t_{DIS}	Disable Time				260	ns
t_{SKEW}	Skew			2		ns
MDR	Maximum Data Rate		4			Mbps

$V_{CCA} = 1.8$ V, $V_{CCB} = 3.3$ V

t_{RB}	B Port Rise Time			34	60	ns
t_{FB}	B Port Fall Time			8	15	ns
t_{RA}	A Port Rise Time			100	110	ns
t_{FA}	A Port Fall Time			5	8	ns
t_{PDAB}	Propagation Delay (A to B)			33	40	ns
t_{PDBA}	Propagation Delay (B to A)			6	11	ns
t_{EN}	Enable Time				125	ns
t_{DIS}	Disable Time				260	ns
t_{SKEW}	Skew			2		ns
MDR	Maximum Data Rate		4			Mbps

$V_{CCA} = 5.5$ V, $V_{CCB} = 1.65$ V

t_{RB}	B Port Rise Time			80	110	ns
t_{FB}	B Port Fall Time			6	9	ns
t_{RA}	A Port Rise Time			7	40	ns
t_{FA}	A Port Fall Time			17	27	ns
t_{PDAB}	Propagation Delay (A to B)			10	17	ns
t_{PDBA}	Propagation Delay (B to A)			27	45	ns
t_{EN}	Enable Time				125	ns
t_{DIS}	Disable Time				260	ns
t_{SKEW}	Skew			2		ns
MDR	Maximum Data Rate		4			Mbps

$V_{CCA} = 5.5$ V, $V_{CCB} = 5.5$ V

t_{RB}	B Port Rise Time			61	70	ns
t_{FB}	B Port Fall Time			6	8	ns
t_{RA}	A Port Rise Time			61	70	ns
t_{FA}	A Port Fall Time			4	7	ns
t_{PDAB}	Propagation Delay (A to B)			4	6	ns

NL5X4002

TIMING CHARACTERISTICS – OPEN DRAIN DRIVING CONFIGURATION (continued)

(Test circuits of Figures 6, 7, 8, 9, 10 and 11, $C_{LOAD} = 15 \text{ pF}$, driver output impedance $\leq 50 \Omega$, $R_{LOAD} = 1 \text{ M}\Omega$, unless otherwise specified. (Notes 6, 7 and 8))

Symbol	Parameter	Conditions	-40 °C to +125 °C			Unit
			Min	Typ	Max	
$V_{CCA} = 5.5 \text{ V}$, $V_{CCB} = 5.5 \text{ V}$						
t_{PDBA}	Propagation Delay (B to A)			6	9	ns
t_{EN}	Enable Time				125	ns
t_{DIS}	Disable Time				260	ns
t_{SKEW}	Skew			2		ns
MDR	Maximum Data Rate		5			Mbps

6. Typical values are for V_{CCA} and V_{CCB} at $T_A = +25 \text{ }^\circ\text{C}$.

7. Limits over the operating temperature range are guaranteed by design.

8. Skew is the variation of propagation delay between output signals and applies only to output signals on the same port (A or B) and switching with the same polarity (LOW-to-HIGH or HIGH-to-LOW). Skew is defined by applying a single input to the two input channels and measuring the difference in propagation delays between the output channels.

TEST SETUPS AND TIMING MEASUREMENTS

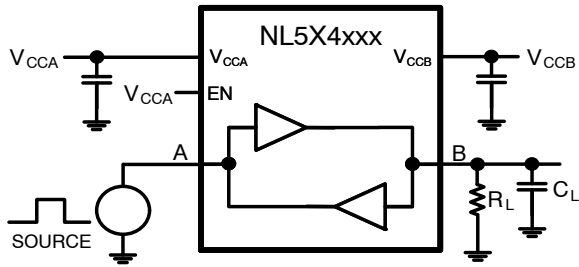

Figure 4. Rail-to-Rail Driving, A to B

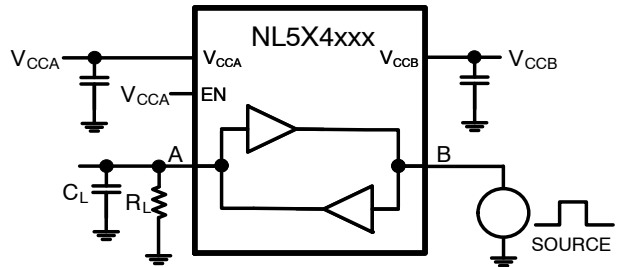

Figure 5. Rail-to-Rail Driving, B to A

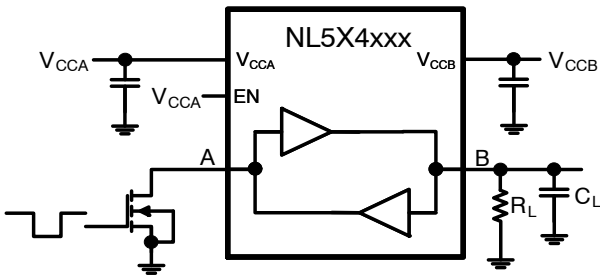

Figure 6. Open-Drain Driving, A to B

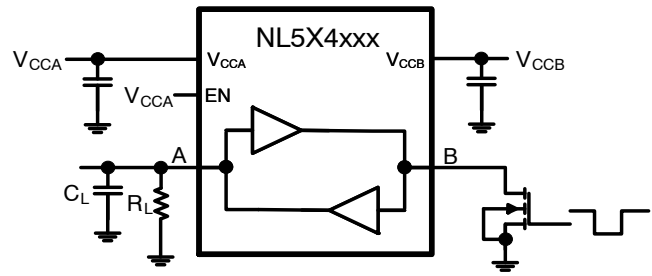

Figure 7. Open-Drain Driving, B to A

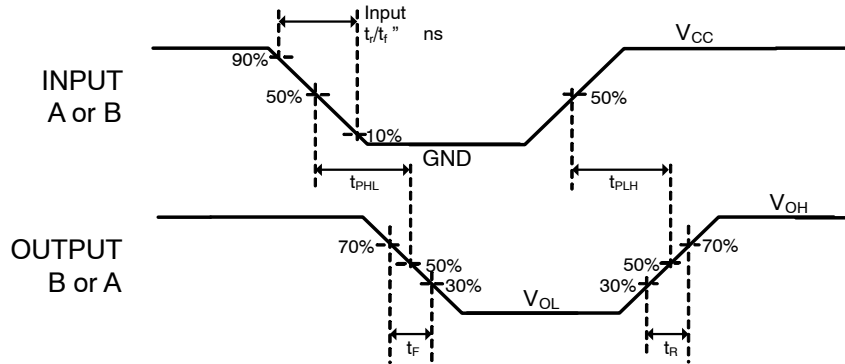

Figure 8. t_{PD} (t_{PHL} , t_{PLH}) and Output t_R / t_F Timing

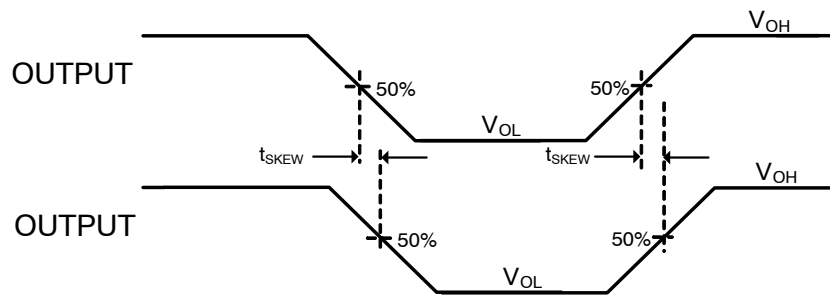

Figure 9. t_{SKEW} Timing

NL5X4002

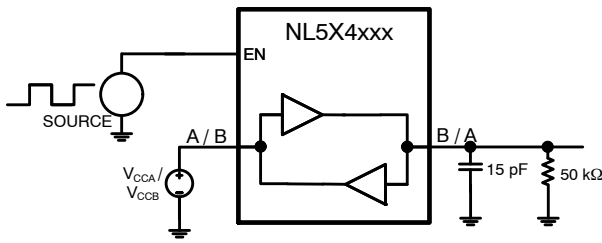

Figure 10. t_{EN}/t_{DIS} Setup for t_{PZH} , t_{PHZ}

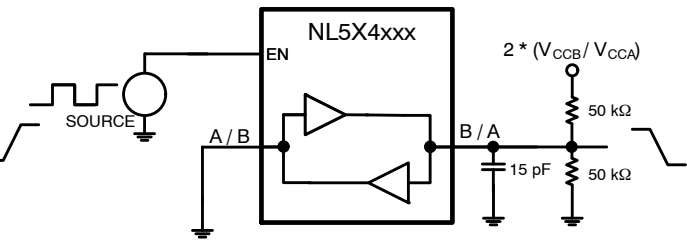

Figure 11. t_{EN}/t_{DIS} Setup for t_{PLZ} , t_{PLZ}

APPLICATIONS INFORMATION

Level Translator Architecture

The NL5X4002 auto sense translator provides bi-directional voltage level shifting to transfer data in multiple supply voltage systems. These devices have two supply voltages, V_{CCA} and V_{CCB} , which set the logic levels on the input and output sides of the translator. When used to transfer data from the A to the B ports, input signals referenced to the V_{CCA} supply are translated to output signals with a logic level matched to V_{CCB} . In a similar manner, the B to A translation shifts input signals with a logic level compatible to V_{CCB} to an output signal matched to V_{CCA} .

These devices consist of two bi-directional channels that independently determine the direction of the data flow without requiring a directional pin. The one-shot circuits detect rising input signals and then decrease the rise times of the output signal for low-to-high transitions.

Each input/output channel of the NL5X4002 translator has an internal 10 k Ω pull-up resistor. The magnitude of the pullup resistors can be reduced by connecting external resistors in parallel with the internal 10 k Ω resistors.

Output Performance

The rise (t_R) and fall (t_F) timing parameters of the open drain outputs depend on the magnitude of the pull-up resistors. In addition, the propagation times (t_{PD}), skew

(t_{SKEW}) and maximum data rate depend on the impedance of the device that is connected to the translator.

Enable Input

These devices have Enable pins (EN) that provide tri-state operation at the I/O pins. Driving the EN pin to a low logic level minimizes the power consumption of the device and drives the A and B ports to high impedance states. Normal translation operation occurs when the EN pin is equal to a logic high signal. The EN pin is referenced to the V_{CCA} supply and has Overvoltage Tolerant (OVT) protection.

Power Supply Guidelines

During normal operation, supply voltage V_{CCA} can be greater than, less than or equal to V_{CCB} . The sequencing of the power supplies will not damage the device during the power up operation.

For optimal performance, 0.01 μ F to 0.1 μ F decoupling capacitors should be used on the V_{CCA} and V_{CCB} power supply pins. Ceramic capacitors are a good design choice to filter and bypass any noise signals on the voltage lines to the ground plane of the PCB. The noise immunity will be maximized by placing the capacitors as close as possible to the supply and ground pins, along with minimizing the PCB connection traces.

NL5X4002

DEVICE ORDERING INFORMATION

Device Order Number	Device Marking	Package Type	Pin 1 Quadrant	Tape & Reel Size [†]
NL5X4002DR2G	5X4002	SO-8	1	2500 / Tape & Reel
NL5X4002DR2G-Q*	5X4002	SO-8	1	2500 / Tape & Reel
NL5X4002DMR2G	4002	Micro8	1	4000 / Tape & Reel
NL5X4002MUTAG	AF	UDFN-8, 1.8x.1.2	1	3000 / Tape & Reel
NL5X4002MUTAG-Q*	AF	UDFN-8, 1.8x.1.2	1	3000 / Tape & Reel

† For information on tape and reel specifications, including part orientation and tape sizes, please refer to our Tape and Reel Packaging Specifications Brochure, [BRD8011/D](#).

* -Q Suffix for Automotive and Other Applications Requiring Unique Site and Control Change Requirements; AEC-Q100 Qualified and PPAP Capable.

Pin 1 Orientation in Tape and Reel

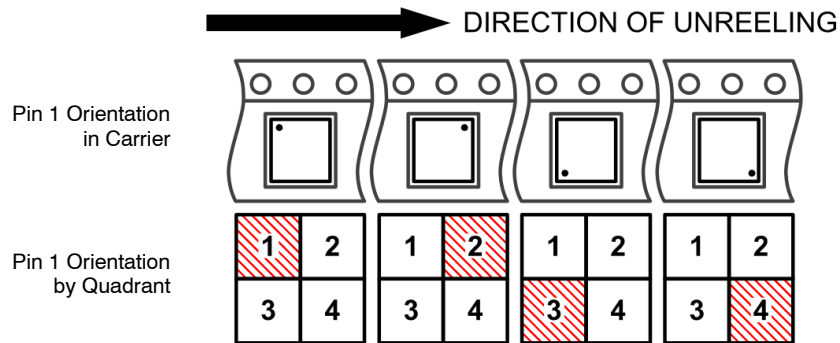

REVISION HISTORY

Revision	Description of Changes	Date
0	Initial release.	06/24/2025
1	Added AEC-Q100 Qualified note under ordering table.	07/25/2025
2	Revision to remove one package order option and three OPNs	02/02/2026

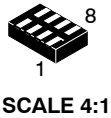

UDFN8 1.8x1.2, 0.4P
CASE 517AJ
ISSUE O

DATE 08 NOV 2006

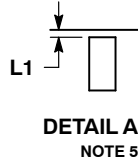
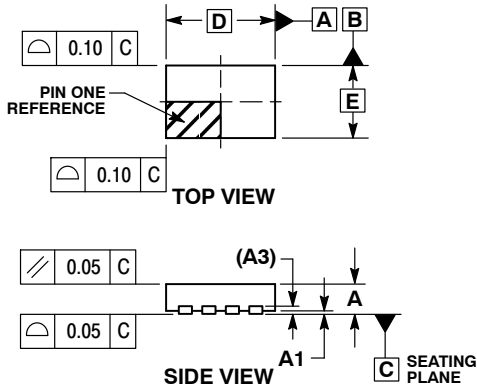

NOTES:

1. DIMENSIONING AND TOLERANCING PER ASME Y14.5M, 1994.
2. CONTROLLING DIMENSION: MILLIMETERS.
3. DIMENSION b APPLIES TO PLATED TERMINAL AND IS MEASURED BETWEEN 0.15 AND 0.30 mm FROM TERMINAL TIP.
4. MOLD FLASH ALLOWED ON TERMINALS ALONG EDGE OF PACKAGE. FLASH MAY NOT EXCEED 0.03 ONTO BOTTOM SURFACE OF TERMINALS.
5. DETAIL A SHOWS OPTIONAL CONSTRUCTION FOR TERMINALS.

MILLIMETERS		
DIM	MIN	MAX
A	0.45	0.55
A1	0.00	0.05
A3	0.127	REF
b	0.15	0.25
b2	0.30	REF
D	1.80	BSC
E	1.20	BSC
e	0.40	BSC
L	0.45	0.55
L1	0.00	0.03
L2	0.40	REF

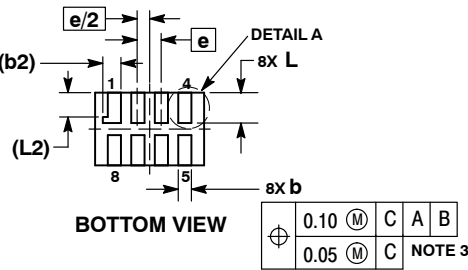

GENERIC MARKING DIAGRAM*

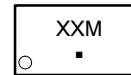

- XX = Specific Device Code
- M = Date Code
- = Pb-Free Package

MOUNTING FOOTPRINT
SOLDERMASK DEFINED

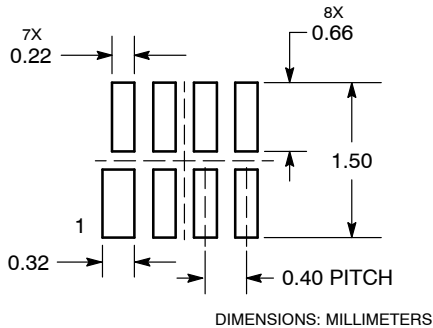

*This information is generic. Please refer to device data sheet for actual part marking. Pb-Free indicator, "G" or microdot "▪", may or may not be present.

DOCUMENT NUMBER:	98AON23417D	Electronic versions are uncontrolled except when accessed directly from the Document Repository. Printed versions are uncontrolled except when stamped "CONTROLLED COPY" in red.
DESCRIPTION:	UDFN8 1.8X1.2, 0.4P	PAGE 1 OF 1

onsemi and ONSEMI are trademarks of Semiconductor Components Industries, LLC dba onsemi or its subsidiaries in the United States and/or other countries. onsemi reserves the right to make changes without further notice to any products herein. onsemi makes no warranty, representation or guarantee regarding the suitability of its products for any particular purpose, nor does onsemi assume any liability arising out of the application or use of any product or circuit, and specifically disclaims any and all liability, including without limitation special, consequential or incidental damages. onsemi does not convey any license under its patent rights nor the rights of others.



SCALE 1:1

SOIC-8 NB
CASE 751-07
ISSUE AK

DATE 16 FEB 2011

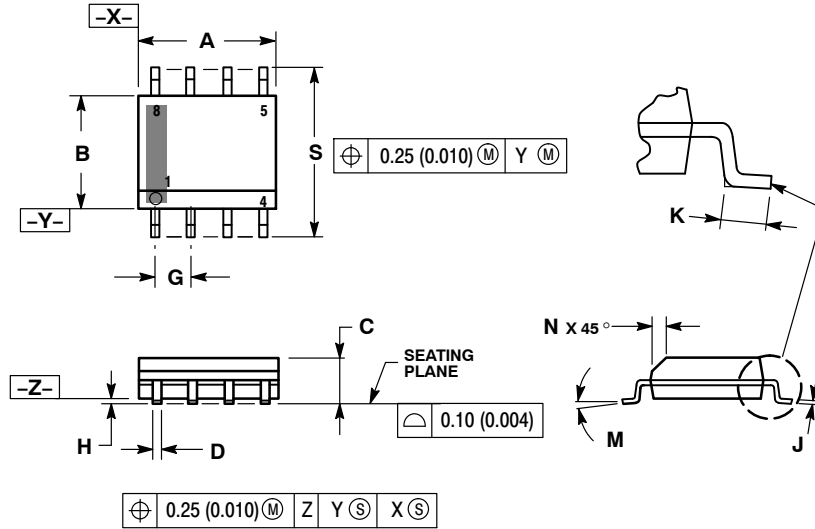

- NOTES:
1. DIMENSIONING AND TOLERANCING PER ANSI Y14.5M, 1982.
 2. CONTROLLING DIMENSION: MILLIMETER.
 3. DIMENSION A AND B DO NOT INCLUDE MOLD PROTRUSION.
 4. MAXIMUM MOLD PROTRUSION 0.15 (0.006) PER SIDE.
 5. DIMENSION D DOES NOT INCLUDE DAMBAR PROTRUSION. ALLOWABLE DAMBAR PROTRUSION SHALL BE 0.127 (0.005) TOTAL IN EXCESS OF THE D DIMENSION AT MAXIMUM MATERIAL CONDITION.
 6. 751-01 THRU 751-06 ARE OBSOLETE. NEW STANDARD IS 751-07.

DIM	MILLIMETERS		INCHES	
	MIN	MAX	MIN	MAX
A	4.80	5.00	0.189	0.197
B	3.80	4.00	0.150	0.157
C	1.35	1.75	0.053	0.069
D	0.33	0.51	0.013	0.020
G	1.27 BSC		0.050 BSC	
H	0.10	0.25	0.004	0.010
J	0.19	0.25	0.007	0.010
K	0.40	1.27	0.016	0.050
M	0°	8°	0°	8°
N	0.25	0.50	0.010	0.020
S	5.80	6.20	0.228	0.244

SOLDERING FOOTPRINT*



*For additional information on our Pb-Free strategy and soldering details, please download the onsemi Soldering and Mounting Techniques Reference Manual, SOLDERRM/D.

GENERIC MARKING DIAGRAM*



XXXXXX = Specific Device Code
A = Assembly Location
L = Wafer Lot
Y = Year
W = Work Week
▪ = Pb-Free Package

XXXXXX = Specific Device Code
A = Assembly Location
Y = Year
WW = Work Week
▪ = Pb-Free Package

*This information is generic. Please refer to device data sheet for actual part marking. Pb-Free indicator, "G" or microdot "▪", may or may not be present. Some products may not follow the Generic Marking.

STYLES ON PAGE 2

DOCUMENT NUMBER:	98ASB42564B	Electronic versions are uncontrolled except when accessed directly from the Document Repository. Printed versions are uncontrolled except when stamped "CONTROLLED COPY" in red.
DESCRIPTION:	SOIC-8 NB	PAGE 1 OF 2

onsemi and onsemi are trademarks of Semiconductor Components Industries, LLC dba onsemi or its subsidiaries in the United States and/or other countries. onsemi reserves the right to make changes without further notice to any products herein. onsemi makes no warranty, representation or guarantee regarding the suitability of its products for any particular purpose, nor does onsemi assume any liability arising out of the application or use of any product or circuit, and specifically disclaims any and all liability, including without limitation special, consequential or incidental damages. onsemi does not convey any license under its patent rights nor the rights of others.

SOIC-8 NB
CASE 751-07
ISSUE AK

DATE 16 FEB 2011

- | | | | |
|---|--|--|--|
| <p>STYLE 1:
 PIN 1. EMITTER
 2. COLLECTOR
 3. COLLECTOR
 4. EMITTER
 5. EMITTER
 6. BASE
 7. BASE
 8. EMITTER</p> | <p>STYLE 2:
 PIN 1. COLLECTOR, DIE, #1
 2. COLLECTOR, #1
 3. COLLECTOR, #2
 4. COLLECTOR, #2
 5. BASE, #2
 6. EMITTER, #2
 7. BASE, #1
 8. EMITTER, #1</p> | <p>STYLE 3:
 PIN 1. DRAIN, DIE #1
 2. DRAIN, #1
 3. DRAIN, #2
 4. DRAIN, #2
 5. GATE, #2
 6. SOURCE, #2
 7. GATE, #1
 8. SOURCE, #1</p> | <p>STYLE 4:
 PIN 1. ANODE
 2. ANODE
 3. ANODE
 4. ANODE
 5. ANODE
 6. ANODE
 7. ANODE
 8. COMMON CATHODE</p> |
| <p>STYLE 5:
 PIN 1. DRAIN
 2. DRAIN
 3. DRAIN
 4. DRAIN
 5. GATE
 6. GATE
 7. SOURCE
 8. SOURCE</p> | <p>STYLE 6:
 PIN 1. SOURCE
 2. DRAIN
 3. DRAIN
 4. SOURCE
 5. SOURCE
 6. GATE
 7. GATE
 8. SOURCE</p> | <p>STYLE 7:
 PIN 1. INPUT
 2. EXTERNAL BYPASS
 3. THIRD STAGE SOURCE
 4. GROUND
 5. DRAIN
 6. GATE 3
 7. SECOND STAGE Vd
 8. FIRST STAGE Vd</p> | <p>STYLE 8:
 PIN 1. COLLECTOR, DIE #1
 2. BASE, #1
 3. BASE, #2
 4. COLLECTOR, #2
 5. COLLECTOR, #2
 6. EMITTER, #2
 7. EMITTER, #1
 8. COLLECTOR, #1</p> |
| <p>STYLE 9:
 PIN 1. EMITTER, COMMON
 2. COLLECTOR, DIE #1
 3. COLLECTOR, DIE #2
 4. EMITTER, COMMON
 5. EMITTER, COMMON
 6. BASE, DIE #2
 7. BASE, DIE #1
 8. EMITTER, COMMON</p> | <p>STYLE 10:
 PIN 1. GROUND
 2. BIAS 1
 3. OUTPUT
 4. GROUND
 5. GROUND
 6. BIAS 2
 7. INPUT
 8. GROUND</p> | <p>STYLE 11:
 PIN 1. SOURCE 1
 2. GATE 1
 3. SOURCE 2
 4. GATE 2
 5. DRAIN 2
 6. DRAIN 2
 7. DRAIN 1
 8. DRAIN 1</p> | <p>STYLE 12:
 PIN 1. SOURCE
 2. SOURCE
 3. SOURCE
 4. GATE
 5. DRAIN
 6. DRAIN
 7. DRAIN
 8. DRAIN</p> |
| <p>STYLE 13:
 PIN 1. N.C.
 2. SOURCE
 3. SOURCE
 4. GATE
 5. DRAIN
 6. DRAIN
 7. DRAIN
 8. DRAIN</p> | <p>STYLE 14:
 PIN 1. N-SOURCE
 2. N-GATE
 3. P-SOURCE
 4. P-GATE
 5. P-DRAIN
 6. P-DRAIN
 7. N-DRAIN
 8. N-DRAIN</p> | <p>STYLE 15:
 PIN 1. ANODE 1
 2. ANODE 1
 3. ANODE 1
 4. ANODE 1
 5. CATHODE, COMMON
 6. CATHODE, COMMON
 7. CATHODE, COMMON
 8. CATHODE, COMMON</p> | <p>STYLE 16:
 PIN 1. EMITTER, DIE #1
 2. BASE, DIE #1
 3. EMITTER, DIE #2
 4. BASE, DIE #2
 5. COLLECTOR, DIE #2
 6. COLLECTOR, DIE #2
 7. COLLECTOR, DIE #1
 8. COLLECTOR, DIE #1</p> |
| <p>STYLE 17:
 PIN 1. VCC
 2. V2OUT
 3. V1OUT
 4. TXE
 5. RXE
 6. VEE
 7. GND
 8. ACC</p> | <p>STYLE 18:
 PIN 1. ANODE
 2. ANODE
 3. SOURCE
 4. GATE
 5. DRAIN
 6. DRAIN
 7. CATHODE
 8. CATHODE</p> | <p>STYLE 19:
 PIN 1. SOURCE 1
 2. GATE 1
 3. SOURCE 2
 4. GATE 2
 5. DRAIN 2
 6. MIRROR 2
 7. DRAIN 1
 8. MIRROR 1</p> | <p>STYLE 20:
 PIN 1. SOURCE (N)
 2. GATE (N)
 3. SOURCE (P)
 4. GATE (P)
 5. DRAIN
 6. DRAIN
 7. DRAIN
 8. DRAIN</p> |
| <p>STYLE 21:
 PIN 1. CATHODE 1
 2. CATHODE 2
 3. CATHODE 3
 4. CATHODE 4
 5. CATHODE 5
 6. COMMON ANODE
 7. COMMON ANODE
 8. CATHODE 6</p> | <p>STYLE 22:
 PIN 1. I/O LINE 1
 2. COMMON CATHODE/VCC
 3. COMMON CATHODE/VCC
 4. I/O LINE 3
 5. COMMON ANODE/GND
 6. I/O LINE 4
 7. I/O LINE 5
 8. COMMON ANODE/GND</p> | <p>STYLE 23:
 PIN 1. LINE 1 IN
 2. COMMON ANODE/GND
 3. COMMON ANODE/GND
 4. LINE 2 IN
 5. LINE 2 OUT
 6. COMMON ANODE/GND
 7. COMMON ANODE/GND
 8. LINE 1 OUT</p> | <p>STYLE 24:
 PIN 1. BASE
 2. EMITTER
 3. COLLECTOR/ANODE
 4. COLLECTOR/ANODE
 5. CATHODE
 6. CATHODE
 7. COLLECTOR/ANODE
 8. COLLECTOR/ANODE</p> |
| <p>STYLE 25:
 PIN 1. VIN
 2. N/C
 3. REXT
 4. GND
 5. IOUT
 6. IOUT
 7. IOUT
 8. IOUT</p> | <p>STYLE 26:
 PIN 1. GND
 2. dv/dt
 3. ENABLE
 4. ILIMIT
 5. SOURCE
 6. SOURCE
 7. SOURCE
 8. VCC</p> | <p>STYLE 27:
 PIN 1. ILIMIT
 2. OVLO
 3. UVLO
 4. INPUT+
 5. SOURCE
 6. SOURCE
 7. SOURCE
 8. DRAIN</p> | <p>STYLE 28:
 PIN 1. SW_TO_GND
 2. DASIC OFF
 3. DASIC_SW_DET
 4. GND
 5. V_MON
 6. VBULK
 7. VBULK
 8. VIN</p> |
| <p>STYLE 29:
 PIN 1. BASE, DIE #1
 2. EMITTER, #1
 3. BASE, #2
 4. EMITTER, #2
 5. COLLECTOR, #2
 6. COLLECTOR, #2
 7. COLLECTOR, #1
 8. COLLECTOR, #1</p> | <p>STYLE 30:
 PIN 1. DRAIN 1
 2. DRAIN 1
 3. GATE 2
 4. SOURCE 2
 5. SOURCE 1/DRAIN 2
 6. SOURCE 1/DRAIN 2
 7. SOURCE 1/DRAIN 2
 8. GATE 1</p> | | |

DOCUMENT NUMBER:	98ASB42564B	Electronic versions are uncontrolled except when accessed directly from the Document Repository. Printed versions are uncontrolled except when stamped "CONTROLLED COPY" in red.
DESCRIPTION:	SOIC-8 NB	PAGE 2 OF 2

onsemi and **ONSEMI** are trademarks of Semiconductor Components Industries, LLC dba **onsemi** or its subsidiaries in the United States and/or other countries. **onsemi** reserves the right to make changes without further notice to any products herein. **onsemi** makes no warranty, representation or guarantee regarding the suitability of its products for any particular purpose, nor does **onsemi** assume any liability arising out of the application or use of any product or circuit, and specifically disclaims any and all liability, including without limitation special, consequential or incidental damages. **onsemi** does not convey any license under its patent rights nor the rights of others.



SCALE 2:1

Micro8
CASE 846A-02
ISSUE K

DATE 16 JUL 2020

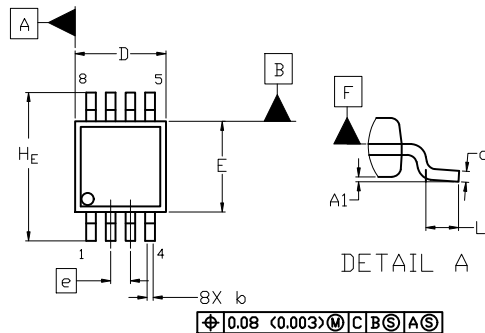

TOP VIEW

NOTE 3

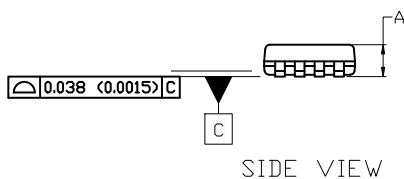

SIDE VIEW

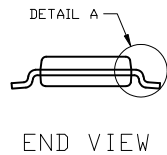

END VIEW

NOTES:

1. DIMENSIONING AND TOLERANCING PER ASME Y14.5M, 2009.
2. CONTROLLING DIMENSION: MILLIMETERS
3. DIMENSION *b* DOES NOT INCLUDE DAMBAR PROTRUSION. ALLOWABLE PROTRUSION SHALL BE 0.10 mm IN EXCESS OF MAXIMUM MATERIAL CONDITION.
4. DIMENSIONS *D* AND *E* DO NOT INCLUDE MOLD FLASH, PROTRUSION OR GATE BURRS. MOLD FLASH, PROTRUSIONS, OR GATE BURRS SHALL NOT EXCEED 0.15 mm PER SIDE. DIMENSION *E* DOES NOT INCLUDE INTERLEAD FLASH OR PROTRUSION. INTERLEAD FLASH OR PROTRUSION SHALL NOT EXCEED 0.25 mm PER SIDE. DIMENSIONS *D* AND *E* ARE DETERMINED AT DATUM *F*.
5. DATUMS *A* AND *B* ARE TO BE DETERMINED AT DATUM *F*.
6. *A1* IS DEFINED AS THE VERTICAL DISTANCE FROM THE SEATING PLANE TO THE LOWEST POINT ON THE PACKAGE BODY.

⌀ 0.08 (0.003) M C B S A S

GENERIC MARKING DIAGRAM*

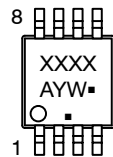

- XXXX = Specific Device Code
- A = Assembly Location
- Y = Year
- W = Work Week
- = Pb-Free Package

(Note: Microdot may be in either location)

*This information is generic. Please refer to device data sheet for actual part marking. Pb-Free indicator, "G" or microdot "▪", may or may not be present. Some products may not follow the Generic Marking.

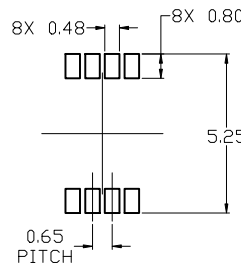

RECOMMENDED MOUNTING FOOTPRINT

For additional information on our Pb-Free strategy and soldering details, please download the ON Semiconductor Soldering and Mounting Techniques Reference Manual, SOLDERM/D.

DIM	MILLIMETERS		
	MIN.	NOM.	MAX.
A	---	---	1.10
A1	0.05	0.08	0.15
b	0.25	0.33	0.40
c	0.13	0.18	0.23
D	2.90	3.00	3.10
E	2.90	3.00	3.10
e	0.65 BSC		
HE	4.75	4.90	5.05
L	0.40	0.55	0.70

STYLE 1:

1. SOURCE
2. SOURCE
3. SOURCE
4. GATE
5. DRAIN
6. DRAIN
7. DRAIN
8. DRAIN

STYLE 2:

1. SOURCE 1
2. GATE 1
3. SOURCE 2
4. GATE 2
5. DRAIN 2
6. DRAIN 2
7. DRAIN 1
8. DRAIN 1

STYLE 3:

1. N-SOURCE
2. N-GATE
3. P-SOURCE
4. P-GATE
5. P-DRAIN
6. P-DRAIN
7. N-DRAIN
8. N-DRAIN

DOCUMENT NUMBER:	98ASB14087C	Electronic versions are uncontrolled except when accessed directly from the Document Repository. Printed versions are uncontrolled except when stamped "CONTROLLED COPY" in red.
DESCRIPTION:	MICRO8	PAGE 1 OF 1

onsemi and ONSEMI are trademarks of Semiconductor Components Industries, LLC dba onsemi or its subsidiaries in the United States and/or other countries. onsemi reserves the right to make changes without further notice to any products herein. onsemi makes no warranty, representation or guarantee regarding the suitability of its products for any particular purpose, nor does onsemi assume any liability arising out of the application or use of any product or circuit, and specifically disclaims any and all liability, including without limitation special, consequential or incidental damages. onsemi does not convey any license under its patent rights nor the rights of others.

onsemi, **Onsemi**, and other names, marks, and brands are registered and/or common law trademarks of Semiconductor Components Industries, LLC dba "**onsemi**" or its affiliates and/or subsidiaries in the United States and/or other countries. **onsemi** owns the rights to a number of patents, trademarks, copyrights, trade secrets, and other intellectual property. A listing of **onsemi**'s product/patent coverage may be accessed at www.onsemi.com/site/pdf/Patent-Marking.pdf. **onsemi** reserves the right to make changes at any time to any products or information herein, without notice. The information herein is provided "as-is" and **onsemi** makes no warranty, representation or guarantee regarding the accuracy of the information, product features, availability, functionality, or suitability of its products for any particular purpose, nor does **onsemi** assume any liability arising out of the application or use of any product or circuit, and specifically disclaims any and all liability, including without limitation special, consequential or incidental damages. Buyer is responsible for its products and applications using **onsemi** products, including compliance with all laws, regulations and safety requirements or standards, regardless of any support or applications information provided by **onsemi**. "Typical" parameters which may be provided in **onsemi** data sheets and/or specifications can and do vary in different applications and actual performance may vary over time. All operating parameters, including "Typicals" must be validated for each customer application by customer's technical experts. **onsemi** does not convey any license under any of its intellectual property rights nor the rights of others. **onsemi** products are not designed, intended, or authorized for use as a critical component in life support systems or any FDA Class 3 medical devices or medical devices with a same or similar classification in a foreign jurisdiction or any devices intended for implantation in the human body. Should Buyer purchase or use **onsemi** products for any such unintended or unauthorized application, Buyer shall indemnify and hold **onsemi** and its officers, employees, subsidiaries, affiliates, and distributors harmless against all claims, costs, damages, and expenses, and reasonable attorney fees arising out of, directly or indirectly, any claim of personal injury or death associated with such unintended or unauthorized use, even if such claim alleges that **onsemi** was negligent regarding the design or manufacture of the part. **onsemi** is an Equal Opportunity/Affirmative Action Employer. This literature is subject to all applicable copyright laws and is not for resale in any manner.

ADDITIONAL INFORMATION

TECHNICAL PUBLICATIONS:

Technical Library: www.onsemi.com/design/resources/technical-documentation
onsemi Website: www.onsemi.com

ONLINE SUPPORT: www.onsemi.com/support

For additional information, please contact your local Sales Representative at www.onsemi.com/support/sales